

Specifications, Installation, Operation Service and Spare Parts Manual

SR-SERIES

Low Intensity Infrared Heater/Radiateur à infrarouge à faible intensité
For either indoor or outdoor installation/Installer à l'intérieur ou à l'extérieur
Also for Brooder Use/Auss pour l'éveage des poules
Industrial, Commercial and Agricultural Applications.

⚠ WARNING: Improper installation, adjustment, alteration, service or maintenance can cause property damage, injury or death. Read the installation operating and maintenance instructions thoroughly before installing or servicing this equipment.

⚠ ADVERTISSEMENT. Une installation, un réglage, une modification, une réparation ou un entretien incorrect peut entraîner des dommages matériels, des blessures ou la mort. Lisez attentivement les instructions d'installation, de fonctionnement et d'entretien avant de procéder à l'installation ou à l'entretien de cet équipement.

⚠ DANGER: What to do if you smell gas:

- 1) Extinguish any open flame
- 2) DO NOT try to light any appliance.
- 3) DO NOT use or touch electrical switches.
- 4) DO NOT use any phone in your building
- 5) Turn off gas.
- 6) Open Windows
- 7) Leave the building
- 8) Immediately call your gas supplier from a neighbour's phone or after you have left the building
- 9) If you cannot reach your gas supplier, call the fire department.

⚠ WARNING: FIRE HAZARD
Do not store or use gasoline or other flammable vapors and liquids in the vicinity of this or any other appliance.

⚠ ADVERTISSEMENT: ILL es interdit d'utiliser des liquids inflammables ou degageant des vapeurs inflammables, a proximite de tout appareil fonctionnant au gaz.

⚠ WARNING:
Heat exchanger surface is hot. Do not touch surface or burn may result. Combustible material or articles should not be placed on or near heater. Observe clearance to combustibles as noted on heater and in this manual.

⚠ ADVERTISSEMENT:

Si vous sentez une odeur de gaz:

1. Ouvrez les fenetres
2. Ne touchez pas aux interrupteurs electriques
3. Eteignez toute flamme nue
4. Contact immediatement votre compangie



USA
Calcana USA Ltd.
30345 Suite A,
County Rd 49
Loxley, AL, 36551
Tel: 251-964-4400
Fax: 251-964-4404

TABLE OF CONTENTS

Table of Figures.....	1
General Information.....	2
Owners Responsibility.....	3
Installers Responsibility.....	4
Code Compliance.....	5
Specifications.....	6
Dimensions.....	7
Clearance to Combustibles.....	8 & 9
Pre-installation Inspection.....	10

Packaging Contents & Description of Parts:

-Burner Package.....	11
-Pipe Boxes.....	11
-10' (3m) Reflector Package.....	12
-15' (4.6m) Reflector Package.....	13
-20' (6.1m) Reflector Package.....	14
-30' (9.1m) Reflector Package.....	15
-40' (12.2m) Reflector Package.....	16
-50' (15.2m) Reflector Package.....	17
-60' (18.3m) Reflector Package.....	18
-70' (21.3m) Reflector Package.....	19
-80' (24.4m) Reflector Package.....	20
-10' (3m) Extension Package.....	21
-Sidewall Reflector Package.....	21
-90° Elbow Package.....	22
-180 ° U-Bend Kit.....	22
-Sidewall Vent Kit.....	23
-Outdoor Installation Kt.....	23

Installation:

-Planning.....	24
-Suspension Points.....	25
-Horizontal Installation 10' (3m) unit.....	25
-Horizontal Installation 15' (4.6m) – 80' (24.4m).....	26
-25° Tilt Installation.....	27
-45° Tilt Installation.....	27

Assembly of Components:

- General Instructions.....	28&29
- Baffle Removal (Transport Position)	30
-Burner Head to First 10' (3m)	30
- Joint Hanger to Reflector	31
- Clamp Coupler	31
- End Cap to Reflector	32
- Baffle/Turbulator Installation	33
- Vent Adaptor Installation	33

Assembly Overview.....	34
-10' (3m) Reflector Package.....	35
-15' (4.6m) Reflector Package.....	36
-20' (6.1m) Reflector Package.....	37

-30' (9.1m) Reflector Package.....	38
-40' (12.2m) Reflector Package.....	39
-50' (15.2m) Reflector Package.....	40
-60' (18.3m) Reflector Package.....	41
-70' (21.3m) Reflector Package.....	42
-80' (24.4m) Reflector Package.....	43
-Sidewall Vent Kit.....	44
-Outdoor Installation Kt.....	44
-90° Elbow Package.....	45
-180 ° U-Bend Kit.....	45
-Sidewall Reflector Package.....	46

Optional Combustion Air Supply	47 & 48
Venting (Sidewall & Roof)	49 to 54
Un-vented Installations	55
Outdoor Applications	56
Gas Piping	57
Gas Connection	58
Checking Gas Input Rate	59 & 60
Electrical Connection	61
Wiring Diagram	62 & 63

Thermostats	
-Low Voltage	64
- Line Voltage	65

Initial Start-Up	66 & 67
Sequence of Operation	68

Troubleshooting

- No Power To Heater	69
- Initial Electrical Check	69
- Initial Gas Checks	70
- Electricity & Gas to Heater but Still Inoperative	70
- Check Control Board	71
- Fault Conditions	71
- Internal Control Fault.....	71
- Air Flow Fault	71
- Flame with No Call For Heat	72
- Ignition Lock Out	72
- Flame Sensor Current Check	72
- Proper Electrode Location	73

Maintenance	74
-------------------	----

Parts:

- Burner Head Parts	75
- Reflector and Tube Parts	76
-Parts List	77to 79

Warranty.....	80
---------------	----

Fuel Conversion.....	81
----------------------	----

TABLE OF FIGURES

Figure #	Description	Page #	Figure #	Description	Page #
1	Equipment Dimensions.....	6	40	End Cap Installation.....	32
2	Unvented Clearances.....	7	41	Baffle Installation.....	33
3	Vented Clearances.....	7	42	Baffle/Turbulator + Flue Adaptor Installation.....	33
4	Installation Type 1.....	8	43	10' (3m) Reflector Package Install...12	
5	Installation Type 2.....	8	44	15' (4.6m) Reflector Package Install...13	
6	Installation Type 3.....	8	45	20' (6.1m) Reflector Package Install...14	
7	Installation Type 4.....	8	46	30' (9.1m) Reflector Package Install...15	
8	Installation Type 5.....	8	47	40' (12.2m) Reflector Package Install...16	
9	Installation Type 6.....	9	48	50' (15.2m) Reflector Package Install...17	
13	Burner Package Contents.....	11	49	60' (18.3m) Reflector Package Install...18	
14	Pipe Box Contents.....	11	50	70' (21.3m) Reflector Package Install...19	
15	10' (3m) Reflector Package.....12		51	80' (24.4m) Reflector Package Install...20	
16	15' (4.6m) Reflector Package.....13		52	Sidewall Vent Kit Installation.....	44
17	20' (6.1m) Reflector Package.....14		53	Outdoor installation Kit.....	44
18	30' (9.1m) Reflector Package.....15		54	90° Elbow Kit Installation.....	45
19	40' (12.2m) Reflector Package.....16		55	180° U-Bend Kit Installation.....	45
20	50' (15.2m) Reflector Package.....17		56	Side Reflector Installation.....	46
21	60' (18.3m) Reflector Package.....18		57	Outside Combustion Air Supply.....	48
22	70' (21.3m) Reflector Package.....19		58	Sidewall Venting, Single Unit.....	51
23	80' (24.4m) Reflector Package.....20		59	Horizontal Sidewall Venting, Two Units Into One Common Vent.....	52
24	10' (3m) Extension Package.....21			Vertical Venting, Single Unit.....	53
25	Sidewall Reflector Package.....21		61	Common Vertical Venting, Two or More Units into One Common Vent.....	54
26	90° Elbow Package.....22		62	Unvented Installation.....	55
27	180 ° U-Bend Kit.....22		63	Outdoor Installation.....	56
28	Sidewall Vent Kit.....23		64	Gas Line Connection with Certified Flexible Gas Connector.....	58
29	Outdoor Installation Package Contents.....	23	65	Electrical Junction Box.....	61
30	Suspension Details.....	25	66	Burner Assembly Wiring Diagram.....	62
31	Horizontal Installation -10' (3m) Package.....	25	67	Burner Assembly Wiring Diagram Ladder Diagram.....	63
32	Horizontal Installations -15' (4.6m) – 80' (24.4m) Package.....	26	68	Low Voltage Thermostat Wiring.....	64
33	25° Tilt.....	27	69	Line Voltage Thermostat Wiring.....	65
34	45° Tilt.....	27	70	Gas Valve.....	67
35	Baffle Removal from Transport Position.....	30	71	Pressure Regulator.....	67
36	Burner Head Installation.....	30	72	Flame Sensor Current Check.....	72
37	Joint Hanger Installation.....	31	73	Proper Electrode Location.....	73
38	Tube Clamp Installation.....	31	74	Burner Head Parts.....	75
			75	Reflector and Tube Parts.....	76

GENERAL INFORMATION

Thank you for purchasing our product. We have designed this unit to provide you with years of trouble-free heating enjoyment. Please take the time to read this manual in its entirety. It will familiarize you with the unit and its operation. Store this manual in a location near the heater for future reference.

Important Notice — These instructions are for the use of qualified individuals specially trained, licensed and experienced in the installation of this type of equipment and related system components.

****Note** — The words “shall” or “must” indicate a requirement which is essential to satisfactory and safe performance.

⚠ WARNING:

The heater and related gas piping, fitting & wiring must be installed by individuals or firms qualified, licensed and specially trained and experienced in installation of this type of equipment and related system components.

Only persons who can understand and follow the instructions shall install or service this heater.

Persons not qualified shall not install this equipment nor interpret these instructions.

Failure to comply with the precautions and instructions provided with this heater can result in death, serious bodily injury and property loss or damage from hazards of fire, explosion, burn, asphyxiation, carbon monoxide poisoning or electrical shock.

⚠ WARNING:

Warranty is void if heater is **NOT** installed by a licensed/qualified gas fitter or contractor: Regular maintenance must be performed prior to heating season. Heaters used in dusty locations such as brooder barns, sawmills, or woodworking shops will require more frequent maintenance. No one should work on a heater unless they are a licensed/qualified gas fitter or contractor. For all repairs, parts **MUST** originate from the manufacturer of this heater in order not to void CGA/AGA certification.

OWNERS RESPONSIBILITY:

⚠ WARNING:

Improper installation, adjustment, alteration, servicing or maintenance can cause property damage, injury or death.

Read this manual in its entirety. Store this manual in a location near the heater, for future reference. Make sure installation is performed by well qualified, licensed contractors in the required field of work. If in doubt, DO NOT allow units to be installed. DO NOT park vehicles or place combustible objects close to the heater, other than specified on the Clearance to Combustibles chart located in this manual and on the heater. Property damage, injury or death could occur. Maintenance is required once a year. Have the heater or heaters inspected before 'the heating season starts. If units are in a dusty environment, maintenance will be required more often. If dusty conditions are extreme, monthly or weekly maintenance may be required, (refer to page 74 titled 'Maintenance')

⚠ WARNING:

Only allow qualified, licensed, service people trained to service gas-fired heating equipment to perform any repairs on this unit. All replacement parts MUST originate from the manufacturer of this heater in order not to void CGALAGA certification. Safety devices are not allowed to be rendered inoperative and left unattended. Failure to do any of the above can cause property damage, injury or death.

⚠ WARNING:

Do not store or use halogen-emitting substances in the vicinity of this heater. Such substances include chlorine based cleaners and swimming pool chemicals, water softening chemicals, de-icing salts and chemicals, cleaning solvents such as carbon tetrachloride or perchloroethylene, halogen type refrigerants, printing inks, paint and paint removers, varnishes, hydrochloric acid, cements and glues, and masonry acid washing materials. 'The air used by the burner for combustion must be free of halogens to avoid possible corrosion to the heating surfaces which could result in asphyxiation, fire and/or death.

INSTALLER RESPONSIBILITY

⚠ WARNING:

FIRE OR EXPLOSION HAZARD

The heater and related gas piping and wiring must be installed only by individuals or firms well qualified and licensed in the required field of work.

Read and understand this manual in its entirety BEFORE you install this heater. If you have any questions call your local representative. Verify that the fuel on the installation site is the same as what is required for this heater. Check heater for damage or missing parts. If damage has occurred, notify carrier or point of purchase at once for reconciliation of damaged goods. We are not responsible for transit damage. Do not install if heater is damaged,

Verify that model, input & length is what was ordered and is appropriate for installation. If heater is too small for the heating load of the building, property damage can occur due to freezing. If unit is too large, severe heat damage can occur to the building and/or its contents, fire, explosion, injury or death. If in doubt compare heat loss of building with unit on site. If you are unable to calculate heat loss call your local representative for assistance.

Installation shall be in accordance with local codes. (see code compliance).

If installation requires tilting, DO NOT over tilt the unit. Units are certified for installations up to 45°, however the maximum recommended tilt is 25°.

Install unit according to the Clearance to Combustibles for that particular heater and type of installation. Make sure that clearances are maintained from vehicles parked below or in front of heater. Take into consideration hoists. Failure to do so could result in property damage, injury or death.

Make sure unit is adequately suspended from ceiling or roof. Select hanging location that has adequate strength to support heater.

If combustion air is contaminated or if there is a negative air pressure in the building, install outside air for combustion. (see pages 47 & 48 titled 'Optional Outside Air').

If unit is to be sidewall vented, use part #5200210 (sidewall vent kit). Make sure vent cap is past eave. (see pages 49, 50, 51 & 52 titled 'Venting').

Do not render safety devices inoperable. Make sure gas line and/or service have adequate capacity for the increased load of heater.

Check line and manifold pressure with a manometer to confirm unit is set according to the specification on the rating plate. Perform check with all gas-fired appliances operating. (see pages 59 & 66 for further details).

Make sure units are operating as quiet and efficient as possible before leaving the job site.

CODE COMPLIANCE

Installation shall be in accordance with local building codes, or in the absence of local codes, in accordance with:

A) FUEL SUPPLY:

CANADA: *Natural Gas and Propane Installation Code, CSA B149.1* or latest edition.

USA: *National Fuel Gas Code, ANSI Z223.1/NFPA 54*, or latest edition.

B) ELECTRICAL GROUNDING:

CANADA: *Canadian Electrical Code, CSA C22.1* or latest edition.

USA: *National Electrical Code, ANSI/NFPA 70* or latest edition

In Canada: Electrical equipment and wiring shall comply with the applicable provisions of the current *Canadian Electrical Code, CAN/CSA C22.1, Part I and Part II, and CAN/CSA C22.2 No. 3, Electrical features of Fuel Burning Equipment.*

C) PUBLIC GARAGE INSTALLATION: Adequate clearances must be maintained according to the following standards:

CANADA: *Natural Gas and Propane Installation Code, CSA B149.1* or latest edition.

USA: *Parking Structures, ANSI/NFPA 88A* or the standard for *Repair Garages, ANSI/NFPA 88B* or latest edition.

D) AIRCRAFT HANGERS: Adequate clearances must be maintained according to the following standards:

CANADA: *Enforcing Authority*

USA: *Aircraft Hangars, ANSI/NFPA 409*

DO NOT INSTALL THIS UNIT IN RESIDENTIAL SPACES

HEATER OPERATION NOTE: Heater will have a higher heat output at the burner end as compared to the exhaust end.

SPACE HEATING: As a general rule, it is suggested to locate the burner end toward the highest heat-loss area (doors) of the space being heated. If you have any concerns or questions concerning orientation or layout of the heater in your application, contact factory for assistance.

SPOT HEATING: On heaters with a straight line configuration as well as units that have the maximum length of radiant tube selected for the input capacity of a given burner, there will be a noticeable and more pronounced perception of greater heat output from the burner end of the heater as compared to the exhaust end. As a general rule, it is suggested for spot heating applications, to use a u-tube configuration to provide a more even source of heat. If you have any concerns or questions concerning orientation or layout of the heater in your application, contact factory for assistance.

NOTE: A small amount of condensation may occur from the heater when it starts the heating cycle. The condensation will stop once the heater warms up. Make sure venting is sealed according to page 49.

General Specifications

Input Rating: (Natural Gas & Propane or LPG fuels)

In Canada: 0-4500' (1372m) In USA: 0-2000' (610m)- Derate above 2000' (610M) (see pg 59)

BURNER INPUT	MINIMUM LENGTH	MAXIMUM LENGTH
40,000 Btu/hr	10' (3m)	20' (6.1m)
50,000 Btu/hr	20' (6.1m)	20' (6.1m)
60,000 Btu/hr	20' (6.1m)	40' (12.2m)
75,000 Btu/hr	20' (6.1m)	40' (12.2m)
80,000 Btu/hr	20' (6.1m)	40' (12.2m)
100,000 Btu/hr	30' (9.1m)	50' (15.2m)
125,000 Btu/hr	40' (12.2m)	50' (15.2m)
150,000 Btu/hr	40' (12.2m)	60' (18.3m)
175,000 Btu/hr	50' (15.2m)	70' (21.3m)
200,000 Btu/hr	60' (18.3m)	80' (24.4m)

Gas Inlet Pressure:	<u>Minimum</u>	<u>Maximum</u>
Natural Gas	4.5" (11.43 cm) W.C.	14.0" (35.56 cm) W.C.
L.P.G (Propane)	11.5" (29.21 cm) W.C.	14.0" (35.56 cm) W.C.

Gas Pressure at Manifold:	
Natural Gas	3.5" (8.89 cm) W.C.
L.P.G (Propane)	10.5" (26.67 cm) W.C.

Gas Connection Size:	0.5" (1.27 cm) N.P.T.
-----------------------------	-----------------------

Flue Connection:	
All Models	4" (10.16 cm)

Combustion Air Intake:	
40,000 to 80,000 Btu/hr input	4" (10.16 cm)
100,000 to 200,000 btu/hr input	6" (15.24 cm)

Electrical Rating:	
DSI Igniton	120v 60hz
1.0 amp	40,000 to 80,000 Btu/hr input
2.25 amp	100,000 to 200,000 Btu/hr input

Standard Equipment:

Burner control housing is pre-assembled and pre-wire, unit comes complete with the following:
 industry standard gas, electrical and venting connections, balanced air rotor, thermal overload protected motor,
 visual burner inspection sight glass, combustion and air proving safety switches, 3-try spark ignition control, low
 voltage thermostat connection, " aluminized combustion tube, " polished aluminum standard reflector, " mild steel
 radiant heat exchanger, tube couplers, joint/hanger pieces, heat economizer baffle/turbulator.

Optional Equipment:

- Side Reflectors
- Aluminized Steel Tube
- Side Wall Vent Kit
- 180° U-Bend Kit
- Stainless Steel Construction
- 90° Elbow Kit
- Thermostat
- Outdoor Installation Kit

DIMENSIONS

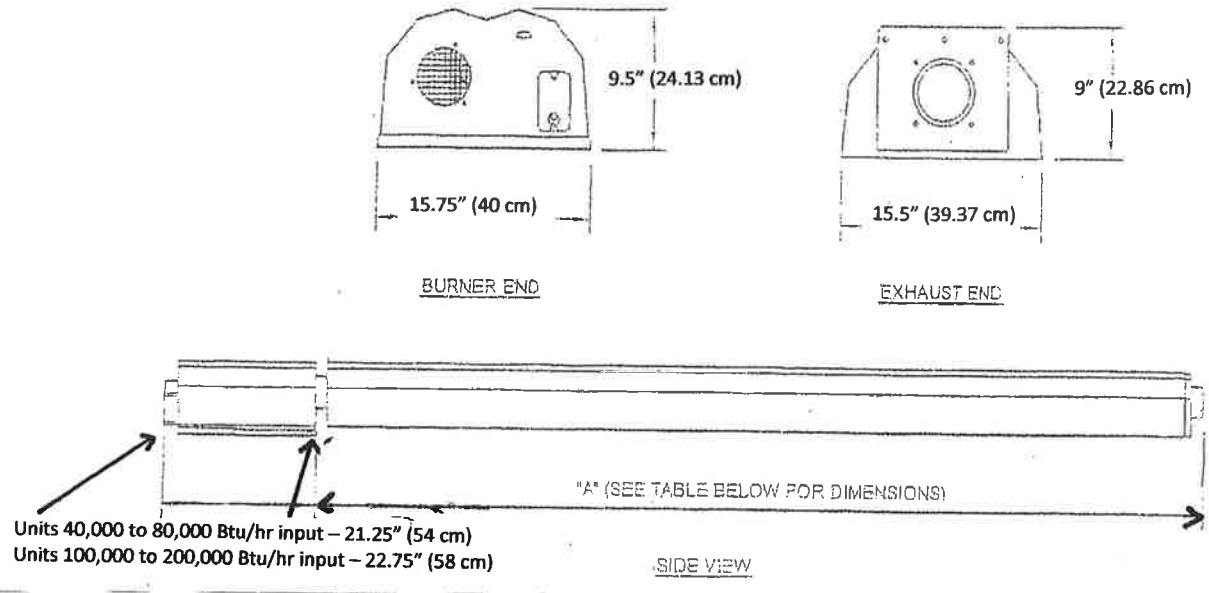

FIGURE #1. EQUIPMENT DIMENSIONS

Table Of Dimensions

UNITS	DIMENSION "A"	
	MINIMUM LENGTH	MAXIMUM LENGTH
BURNER INPUT		
40,000 Btu/hr	10'-4" (3.15m)	20'-4" (6.4m)
50,000 Btu/hr	20'-4" (6.4m)	20'-4" (6.4m)
60,000 Btu/hr	20'-4" (6.4m)	40'-4" (12.3m)
75,000 Btu/hr	20'-4" (6.4m)	40'-4" (12.3m)
80,000 Btu/hr	20'-4" (6.4m)	40'-4" (12.3m)
100,000 Btu/hr	30'-4" (9.25m)	50'-4" (15.3m)
125,000 Btu/hr	40'-4" (12.3m)	50'-4" (15.3m)
150,000 Btu/hr	40'-4" (12.3m)	60'-4" (18.4m)
175,000 Btu/hr	50'-4" (15.3m)	70'-4" (21.5m)
200,000 Btu/hr	60'-4" (18.4m)	80'-4" (24.5m)

CLEARANCE TO COMBUSTIBLES

Installation of overhead heaters in garages or hangars **MUST** meet the requirements for bottom (below) clearances detailed in **CANADA: *Natural Gas and Propane Installation Code, CSA B149.1*** or latest edition or **USA: *National Fuel Gas Code, ANSI Z223.1/NFPA 54***, or latest edition.

The stated clearance to combustibles represents a surface temperature of 90°F (32°C) above room temperature. Building materials with a low heat tolerance (such as plastics, vinyl siding, canvas, tri-ply, etc.) may be subject to degradation at lower temperatures. It is the installer's responsibility to assure that adjacent materials are protected from degradation.

⚠ WARNING: In all situations, clearances to combustibles must be maintained. Minimum clearance from heater must be maintained from vehicles parked below heater. The posting of signs may be required in storage areas referring to clearances to combustibles to the heater and/or limiting the stacking height of stored items near the heater specifying a maximum height. Clearances are not for use in four (4) sided enclosures.

END CLEARANCES

(BURNER HEAD END)

Minimum clearances from air intake end of burner head to object is **12" (30.5 cm)**.

END CLEARANCES

(VENT END)

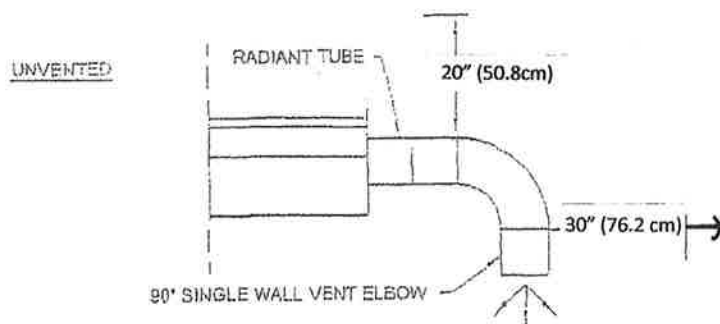

FIGURE #2. UNVENTED CLEARANCES

VENTED

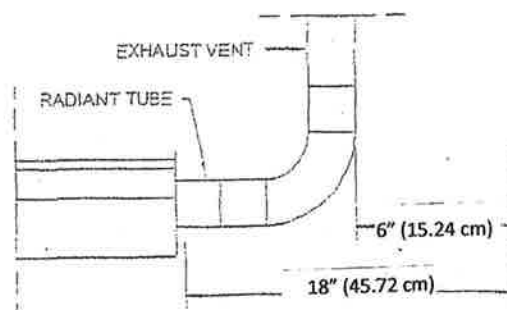

FIGURE #3. VENTED CLEARANCES

CLEARANCE TO COMBUSTIBLES FOR SPACE HEATING AND BROODER INSTALLATION

⚠ WARNING: In all situations, clearance to combustibles must be maintained. Minimum clearance from heater must be maintained from vehicles parked below heater. The posting of signs may be required in storage area(s) referring to clearance to combustibles to the heater and/or limiting the stacking height of stored items near the heater specifying a maximum height. Clearances are not for use in four (4) side enclosures.

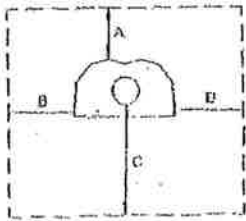

FIGURE #4
STANDARD REFLECTOR

INSTALLATION TYPE 1 - (Inches)				
Input*	A	B	C	D
40	6	12	36	12
50	6	12	36	12
60	6	15	44	15
70	6	20	50	20
80	6	20	53	20
100	6	22	55	22
125	6	22	55	22
150	6	24	60	24
175	6	24	65	24
175+20' **	6	20	45	20
200	6	27	65	27
200+20' **	6	20	45	20

INSTALLATION TYPE 1 - (cm)				
Input*	A	B	C	D
40	16	31	92	31
50	16	31	92	31
60	16	39	112	39
70	16	51	127	51
80	16	51	135	51
100	16	56	140	56
125	16	56	140	56
150	16	70	152	70
175	16	70	152	70
175+20' **	16	51	115	51
200	16	69	165	69
200+20' **	16	51	115	51

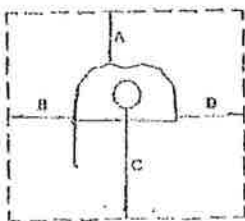

FIGURE #5
ONE SIDE REFLECTOR

INSTALLATION TYPE 2 - (Inches)				
Input*	A	B	C	D
40	6	12	36	36
50	6	12	36	36
60	6	12	44	36
70	6	12	50	36
80	6	20	53	40
100	6	22	55	40
125	6	22	55	40
150	6	24	60	40
175	6	24	65	40
175+20' **	6	16	45	36
200	6	27	65	40
200+20' **	6	16	45	36

INSTALLATION TYPE 2 - (cm)				
Input*	A	B	C	D
40	16	31	92	92
50	16	31	92	92
60	16	31	112	92
70	16	31	127	92
80	16	51	135	102
100	16	56	140	102
125	16	56	140	102
150	16	70	152	102
175	16	70	165	102
175+20' **	16	41	115	92
200	16	69	165	102
200+20' **	16	41	115	92

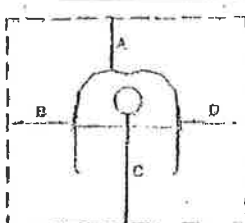

FIGURE #6
TWO SIDE REFLECTOR

INSTALLATION TYPE 3 - (Inches)				
Input*	A	B	C	D
40	6	15	53	15
50	6	20	60	20
60	6	23	66	23
70	6	25	72	25
80	6	25	72	25
100	6	27	78	27
125	6	32	84	32
150	6	32	88	32
175	6	32	88	32
175+20' **	6	24	48	24
200	6	32	88	32
200+20' **	6	24	48	24

INSTALLATION TYPE 3 - (cm)				
Input*	A	B	C	D
40	16	39	135	39
50	16	51	152	51
60	16	59	168	59
70	16	64	183	64
80	16	64	183	64
100	16	69	199	69
125	16	82	214	82
150	16	82	224	82
175	16	82	224	82
175+20' **	16	70	122	70
200	16	82	224	82
200+20' **	16	70	122	70

* per 1,000 btu/hr input ** Clearance 20' (6.1m) downstream from burner

CLEARANCE TO COMBUSTIBLES FOR SPACE HEATING AND BROODER INSTALLATION

⚠ WARNING: In all situations, clearance to combustibles must be maintained. Minimum clearance from heater must be maintained from vehicles parked below heater. The posting of signs may be required in storage area(s) referring to clearance to combustibles to the heater and/or limiting the stacking height of stored items near the heater specifying a maximum height. Clearances are not for use in four (4) side enclosures.

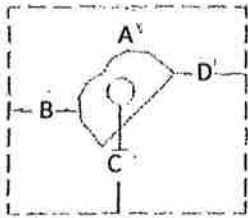

FIGURE #7
25° to 45° Tilt

INSTALLATION TYPE 4 - (Inches)				
Input*	A	B	C	D
40	6	6	36	36
50	6	6	36	36
60	6	6	44	44
70	6	6	50	50
80	6	6	53	53
100	6	6	55	55
125	6	6	55	55
150	6	6	60	60
175	6	6	65	65
175+20' **	6	6	45	45
200	6	6	65	65
200+20' **	6	6	45	45

INSTALLATION TYPE 4 - (cm)				
Input*	A	B	C	D
40	16	16	92	92
50	16	16	92	92
60	16	16	112	112
70	16	16	127	127
80	16	16	135	135
100	16	16	140	140
125	16	16	140	140
150	16	16	152	152
175	16	16	152	152
175+20' **	16	16	115	115
200	16	16	165	165
200+20' **	16	16	115	115

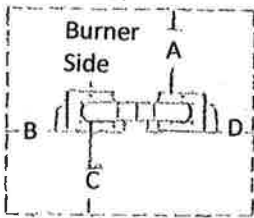

FIGURE #8
U - Tube Standard

INSTALLATION TYPE 5 - (Inches)				
Input*	A	B	C	D
40	6	12	60	12
50	6	12	63	12
60	6	12	63	12
70	6	12	69	12
80	6	20	69	20
100	6	22	76	22
125	6	22	79	22
150	6	24	84	24
175	6	24	86	24
-	-	-	-	-
200	6	27	86	27
-	-	-	-	-

INSTALLATION TYPE 5 - (cm)				
Input*	A	B	C	D
40	16	31	152	31
50	16	31	161	31
60	16	31	161	31
70	16	31	176	31
80	16	51	176	51
100	16	56	194	56
125	16	56	201	56
150	16	70	214	70
175	16	70	219	70
-	-	-	-	-
200	16	69	219	69
-	-	-	-	-

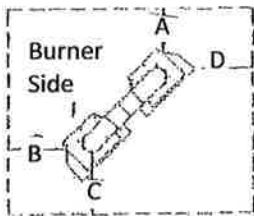

FIGURE #9
25° to 45° Tilt U-Tube

INSTALLATION TYPE 6 - (Inches)				
Input*	A	B	C	D
40	6	6	51	40
50	6	6	57	40
60	6	6	60	43
70	6	6	66	47
80	6	6	66	47
100	6	6	71	53
125	6	6	77	62
150	6	6	80	67
175	6	6	84	70
-	-	-	-	-
200	6	6	94	70
-	-	-	-	-

INSTALLATION TYPE 6 - (cm)				
Input*	A	B	C	D
40	16	16	130	102
50	16	16	145	102
60	16	16	152	110
70	16	16	168	120
80	16	16	168	120
100	16	16	181	135
125	16	16	196	158
150	16	16	204	171
175	16	16	214	178
-	-	-	-	-
200	16	16	214	178
-	-	-	-	-

* per 1,000 btu/hr input ** Clearance 20' (6.1m) downstream from burner

PRE-INSTALLATION INSPECTION:

Refer to pages 11 to 23 for packaging contents.

Inspect the shipping container and heater for any evidence of shipping damage. If heater damage is found, notify freight carrier and file a claim.

⚠ WARNING: If heater is damaged, DO NOT install.

Check that all parts and pieces are present and accounted for. Report any missing items to carrier or point of purchase at once.

Check that overall general appearance, source of fuel required and model numbers match unit requested. Report any discrepancy to carrier or point of purchase at once.

**THOROUGHLY INSPECT THE EQUIPMENT
IMMEDIATELY UPON ARRIVAL**

OUR RESPONSIBILITY FOR THIS SHIPMENT CEASED WHEN THE CARRIER SIGNED THE WAYBILL.

If goods are received short or in damage condition, it is important that you notify the carrier and insist on a notation of the loss or damage across the face of the freight bill, otherwise no claim can be enforced against the transportation company.

If concealed loss or damage is discovered, notify your carrier at once and request an inspection. This is absolutely necessary. A concealed damage report must be made within 15-days of delivery of shipment. Unless you do this the carrier will not entertain any claim for loss or damage. The Agent will make an inspection and grant a concealed damage notation. If you give the Transportation Company a clear receipt for goods that have been damaged or lost in transit you do so at your own risk and expense.

WE ARE WILLING TO ASSIST YOU IN EVERY POSSIBLE MANNER TO COLLECT CLAIMS FOR LOSS OR DAMAGE, BUT THIS WILLINGNESS ON OURPART DOES NOT MAKE US RESPONSIBLE FOR COLLECTION OF CLAIMS OR REPLACEMENT

WE ARE NOT RESPONSIBLE FOR FREIGHT DAMAGED IN TRANSIT!

IF CONTENTS ARE DAMAGED,
EVEN TROUGH CARTON DOES NOT LOOK DAMAGED:

- A. MAKE CLAIM TO DELIVERY CARRIER AT ONCE
- B. SAVE CARTONS FOR INSPECTION BY CARRIER

PACKAGING CONTENTS & DESCRIPTION OF PARTS

11

A) BURNER PACKAGE

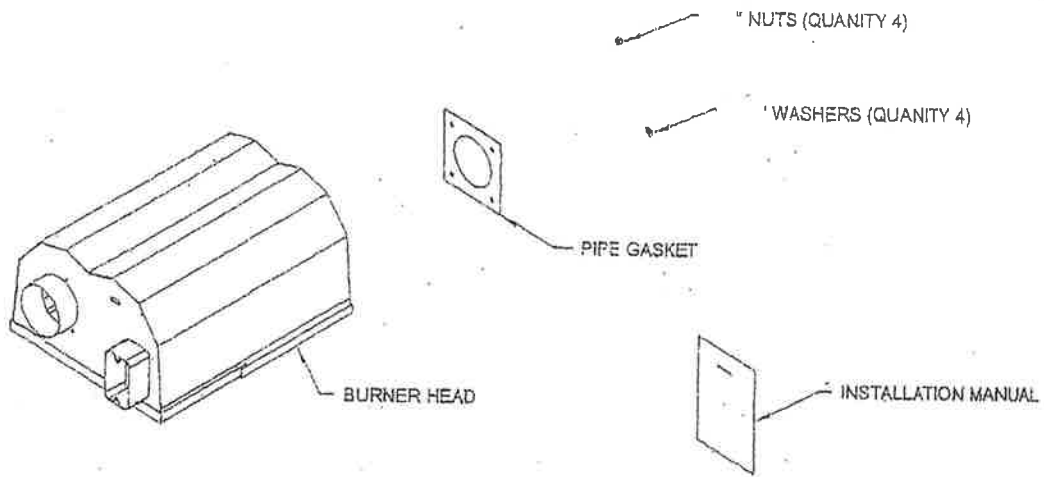

FIGURE #13. BURNER PACKAGE CONTENTS

B) PIPE BOXES

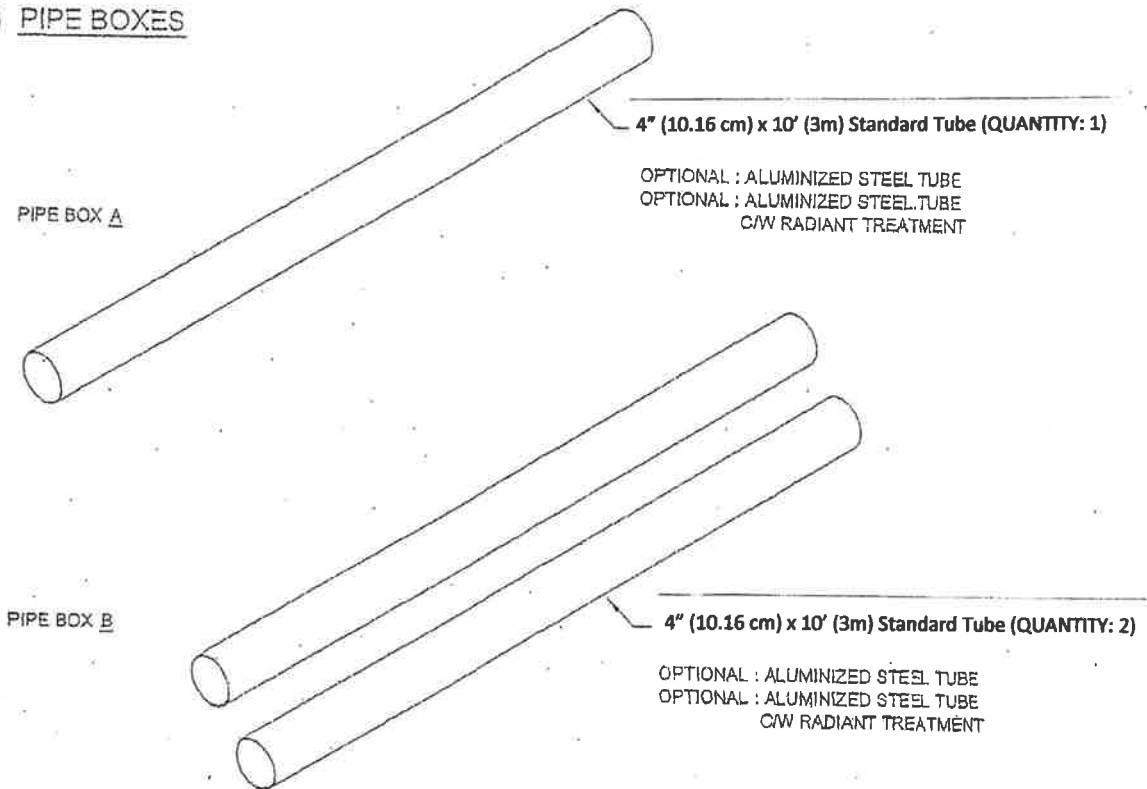
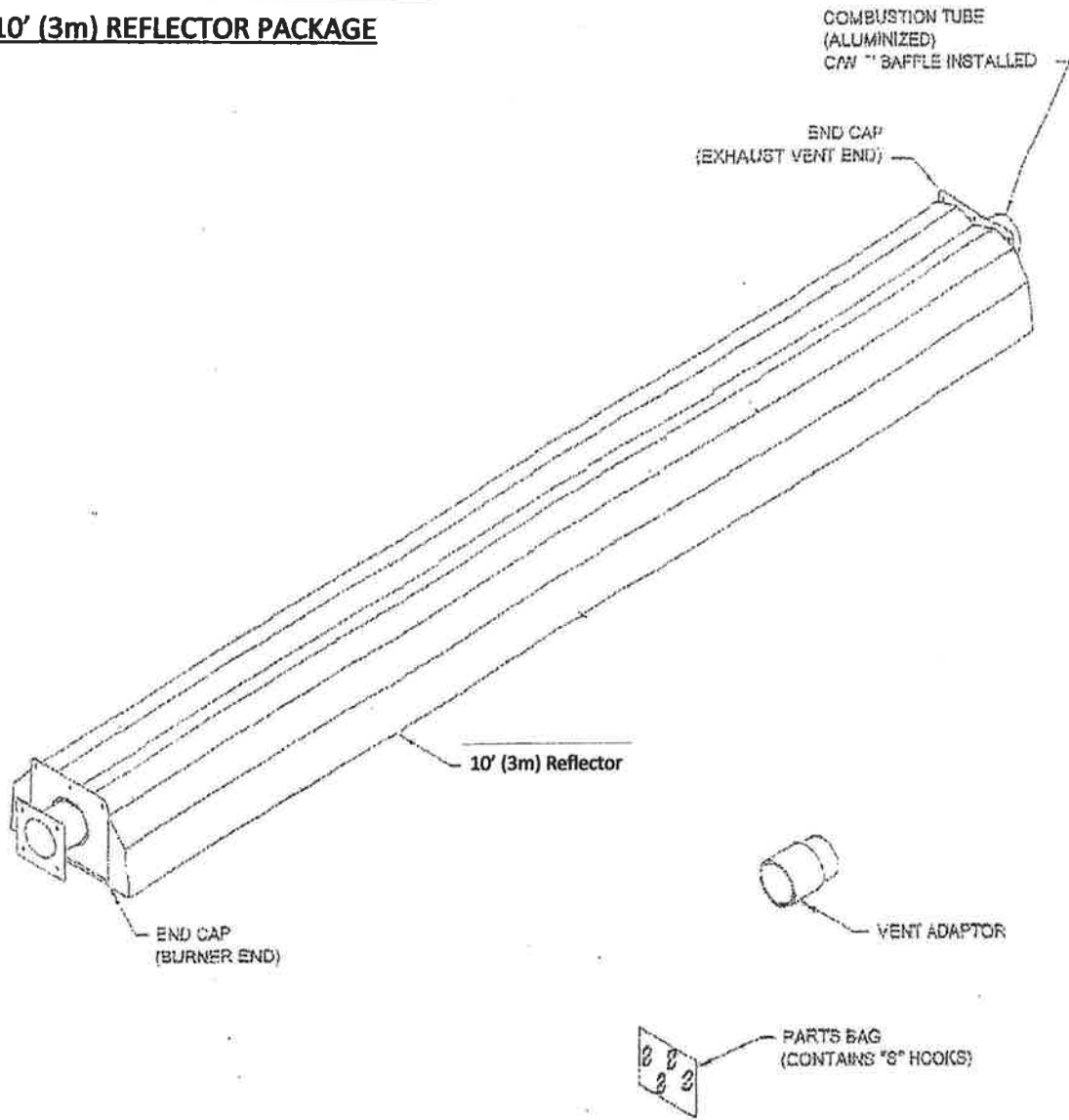

FIGURE #14. PIPE BOX CONTENTS

C) 10' (3m) REFLECTOR PACKAGE



FIGURE#15. 10' (3m) Reflector Package Contents

D) 15' (4.6m) REFLECTOR PACKAGE

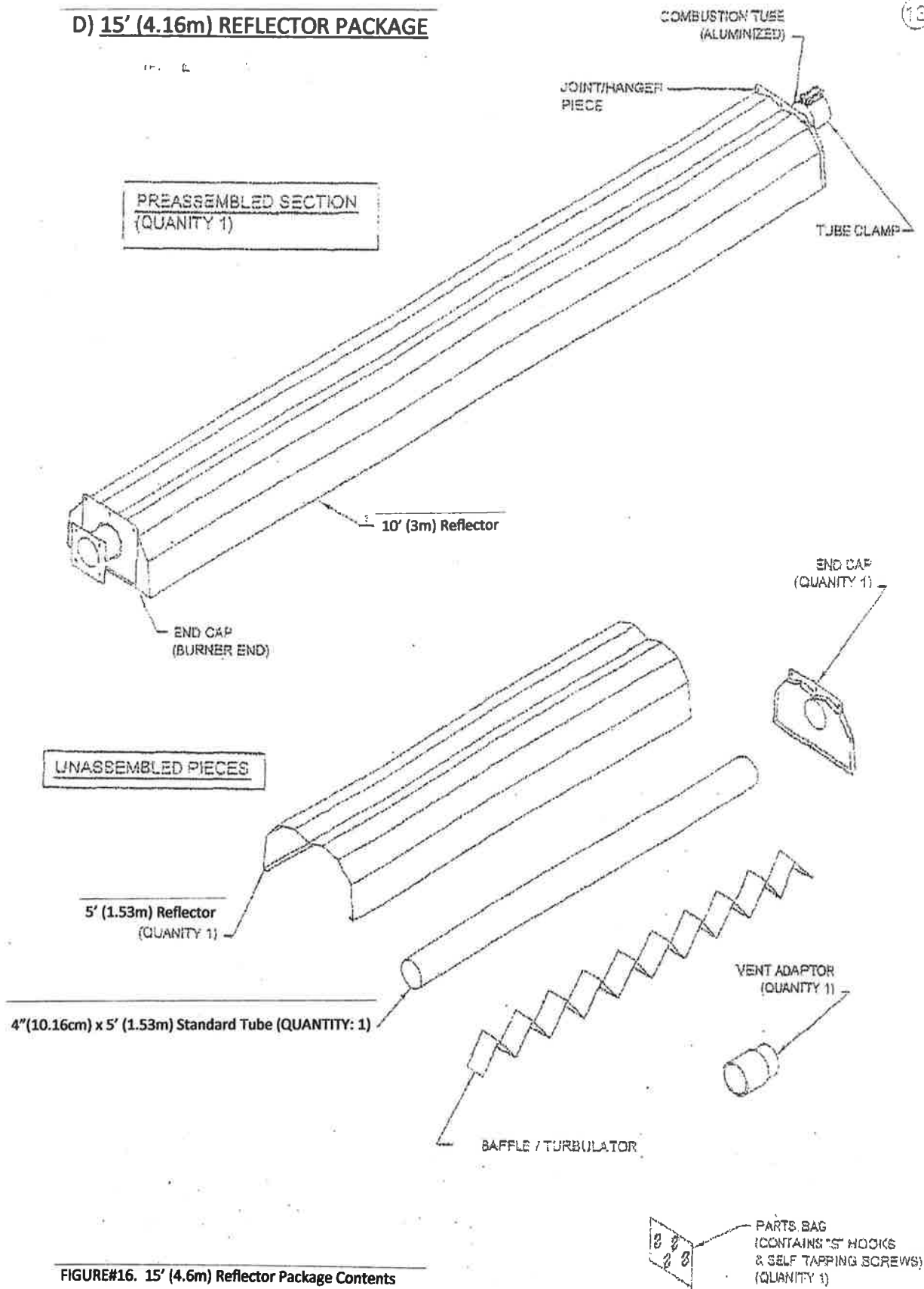

FIGURE#16. 15' (4.6m) Reflector Package Contents

E) 20' (6.1m) REFLECTOR PACKAGE

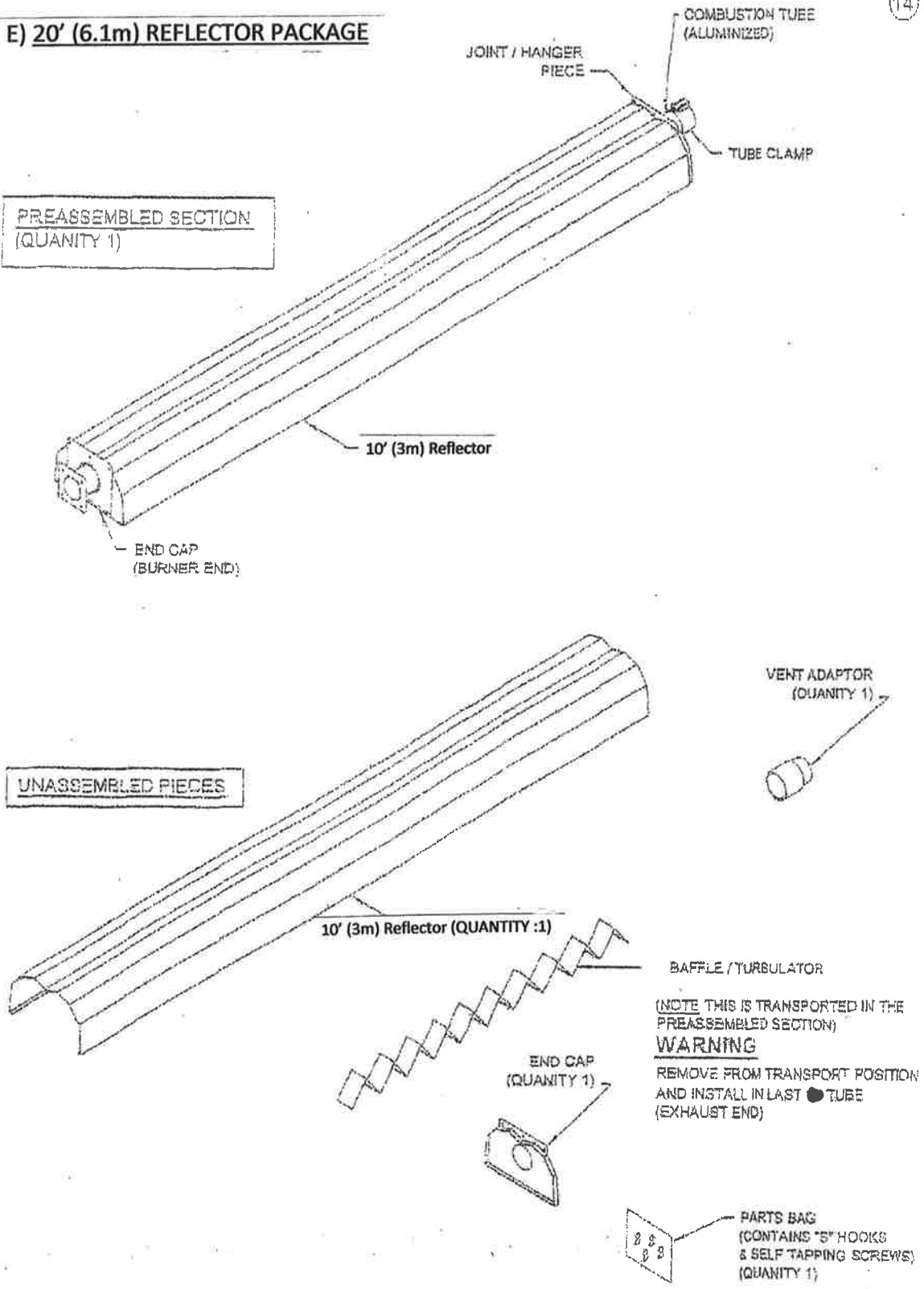

FIGURE#17. 20' (6.1m) Reflector Package Contents

F) 30' (9.1m) REFLECTOR PACKAGE

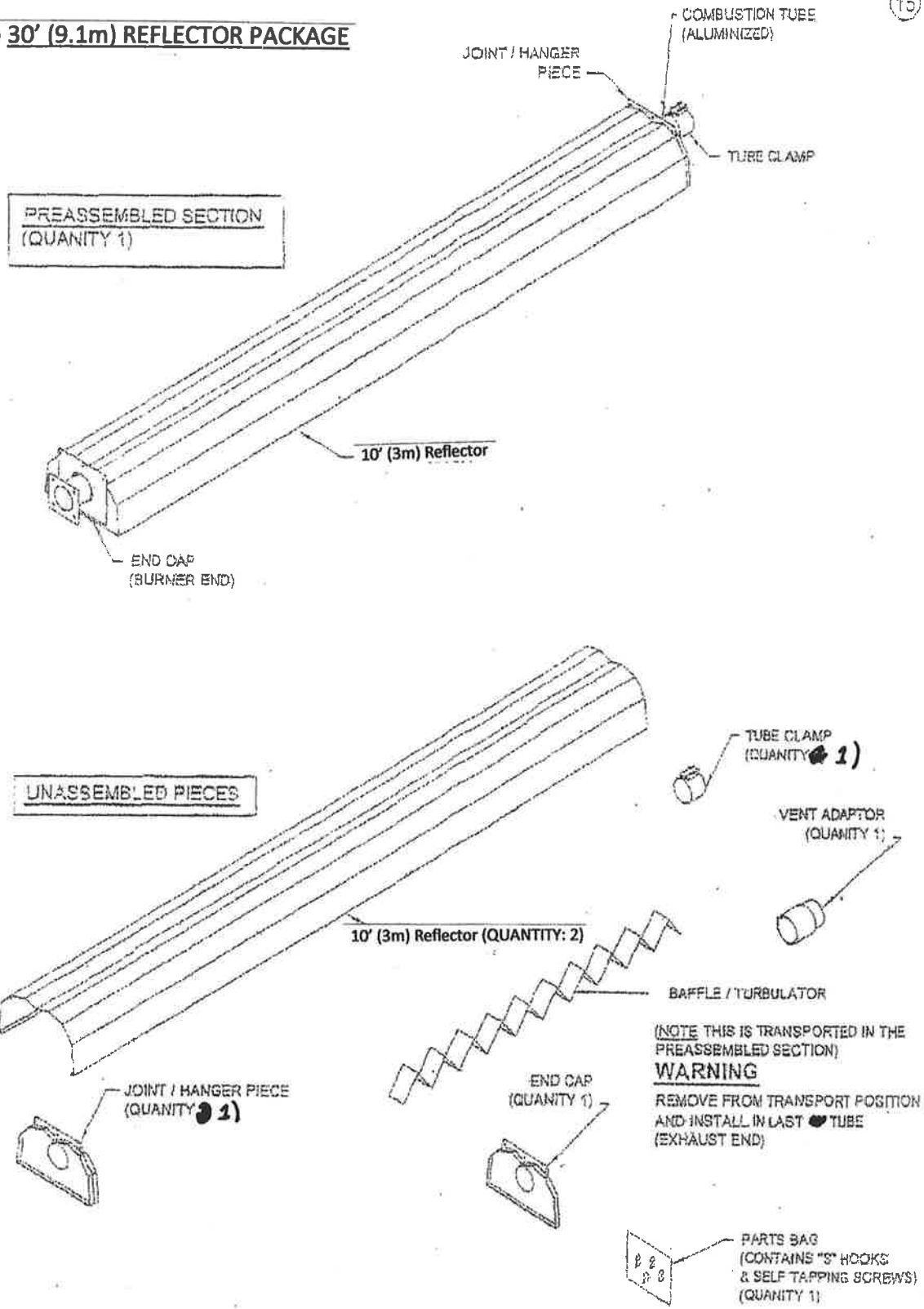

FIGURE#18. 30' (9.1m) Reflector Package Contents

G) 40' (12.2m) REFLECTOR PACKAGE

PREASSEMBLED SECTION
(QUANTITY 1)

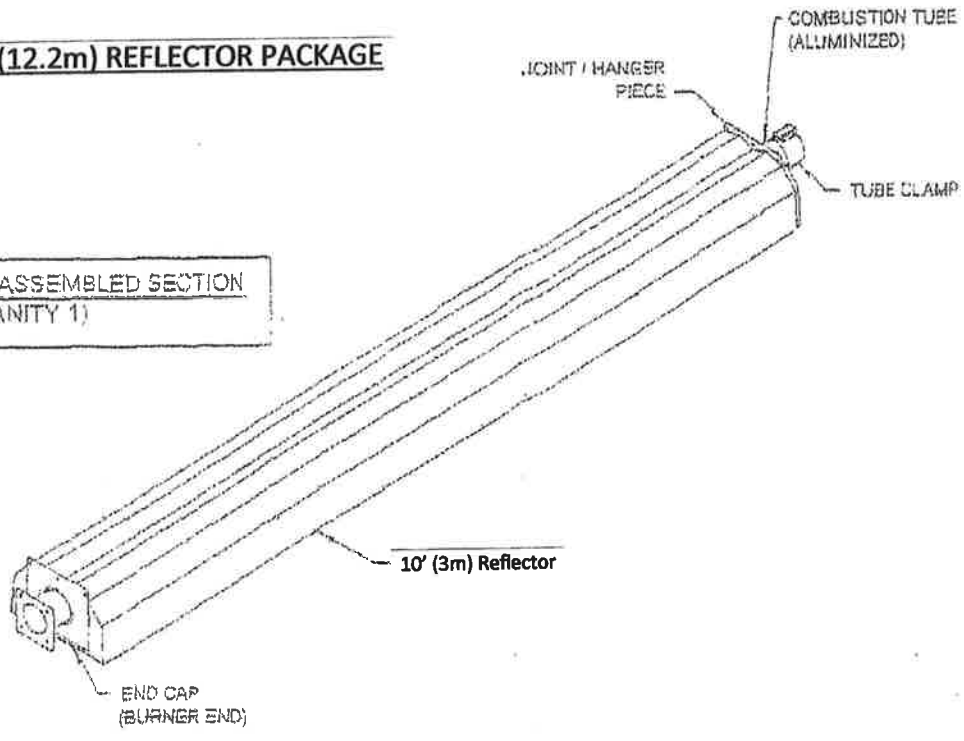

UNASSEMBLED PIECES

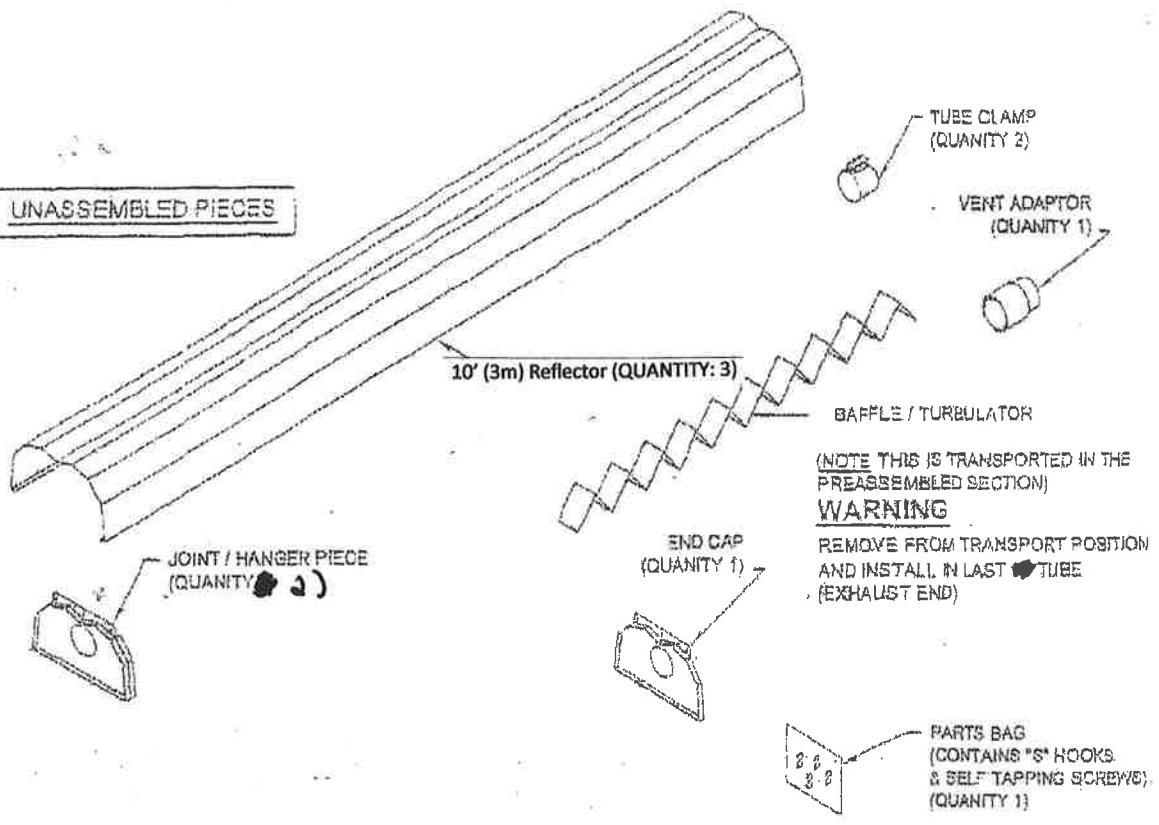

FIGURE#19. 40' (12.2m) Reflector Package Contents

H) 50' (15.2m) REFLECTOR PACKAGE

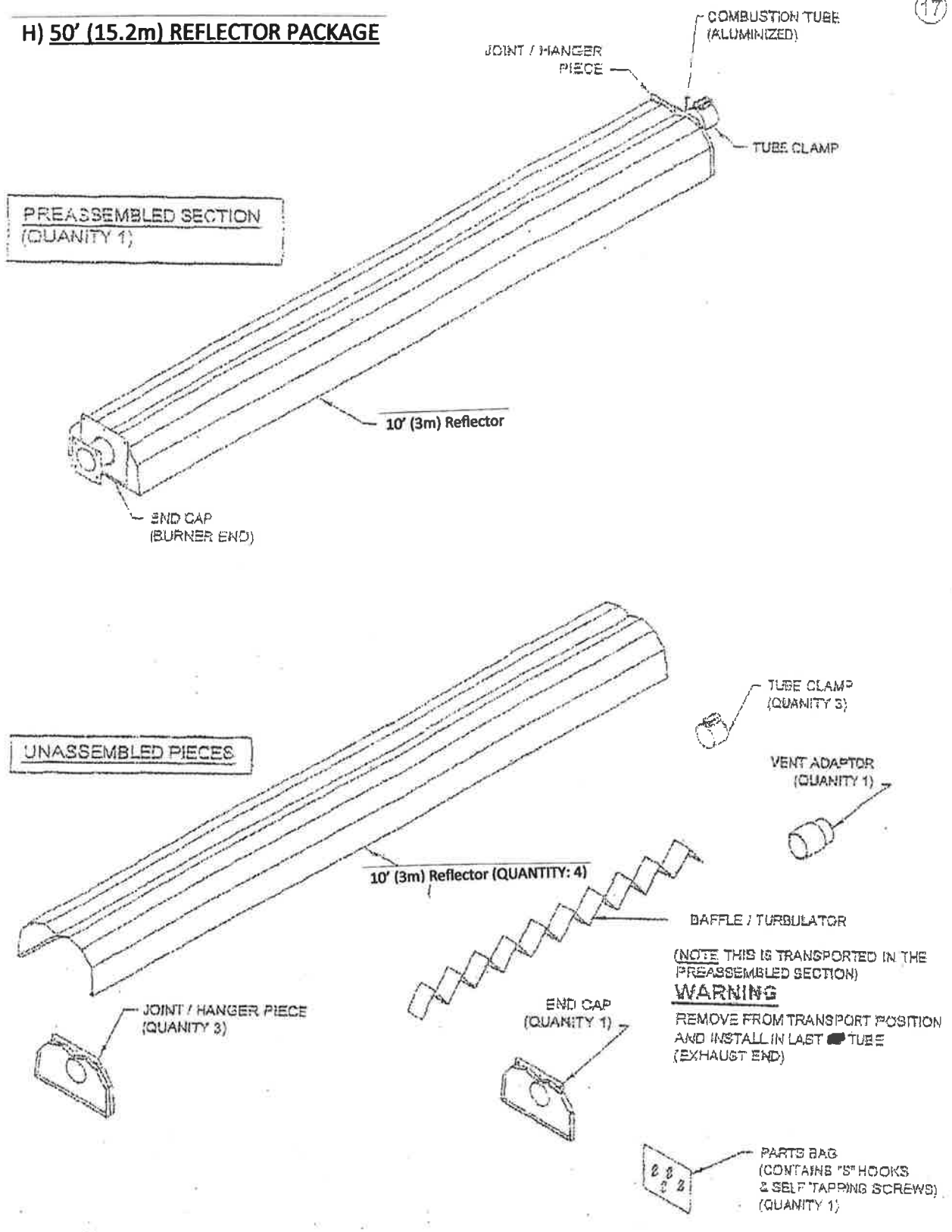

FIGURE#20. 50' (15.2m) Reflector Package Contents :

1) 60' (18.3m) REFLECTOR PACKAGE

PREASSEMBLED SECTION
(QUANTITY 1)

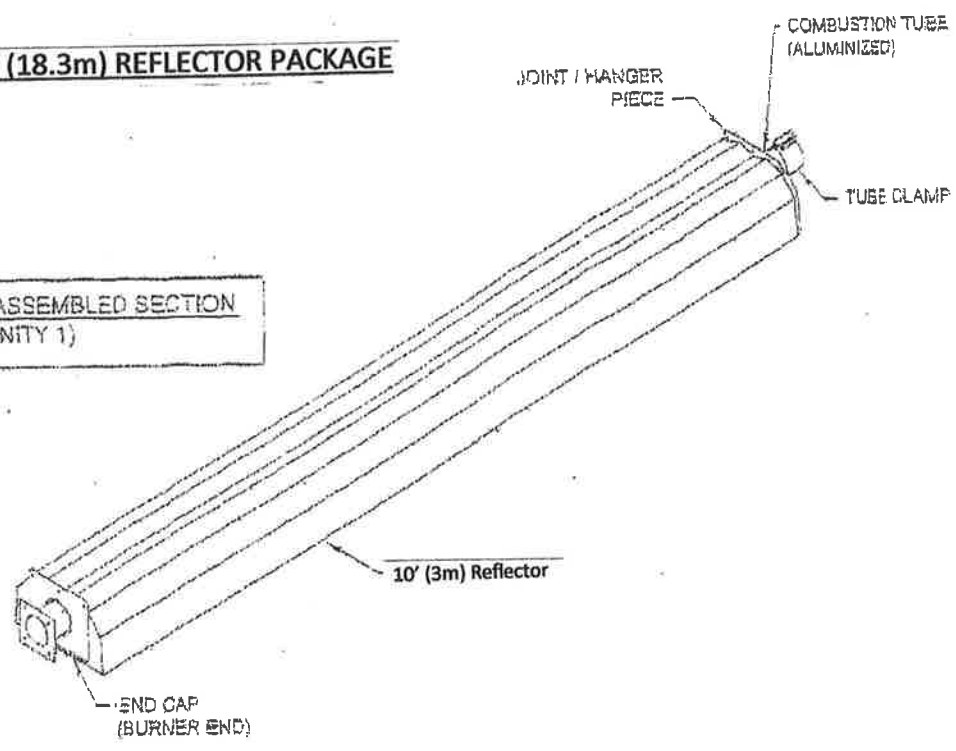

UNASSEMBLED PIECES

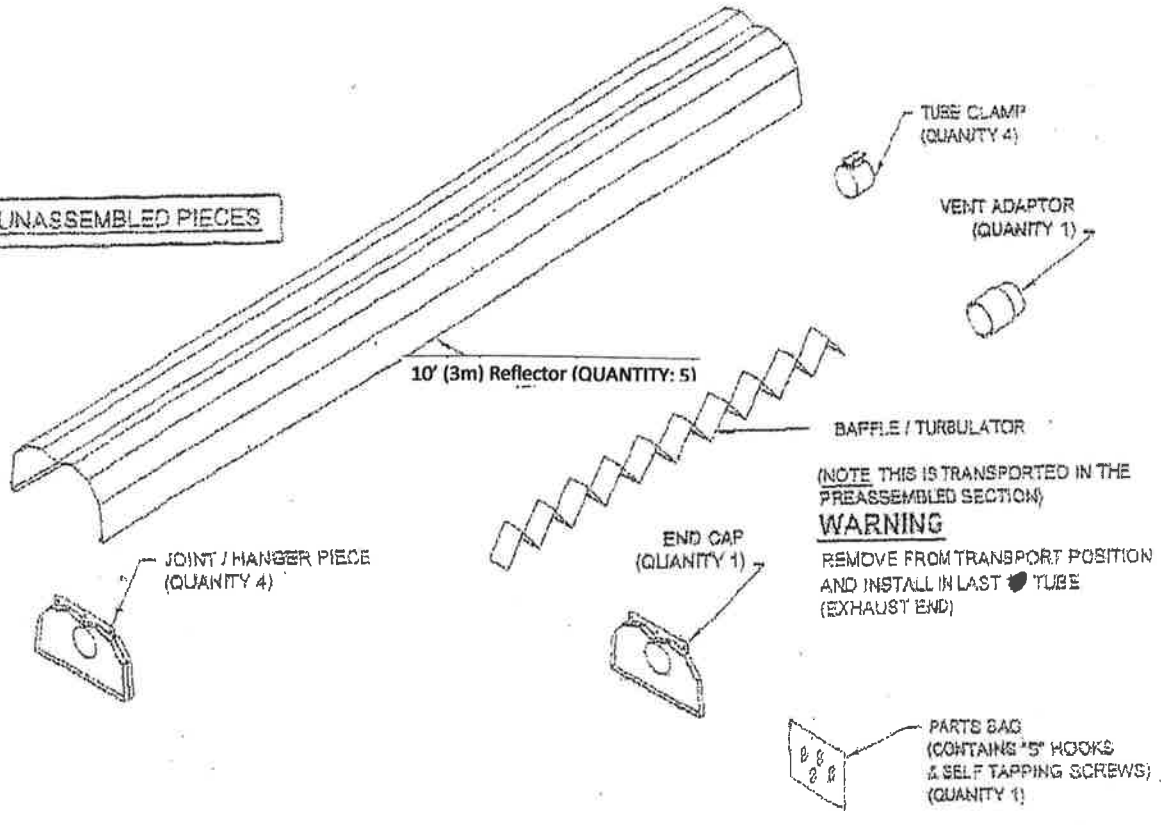

FIGURE#21. 60' (18.3m) Reflector Package Contents

J) 70' (21.3m) REFLECTOR PACKAGE

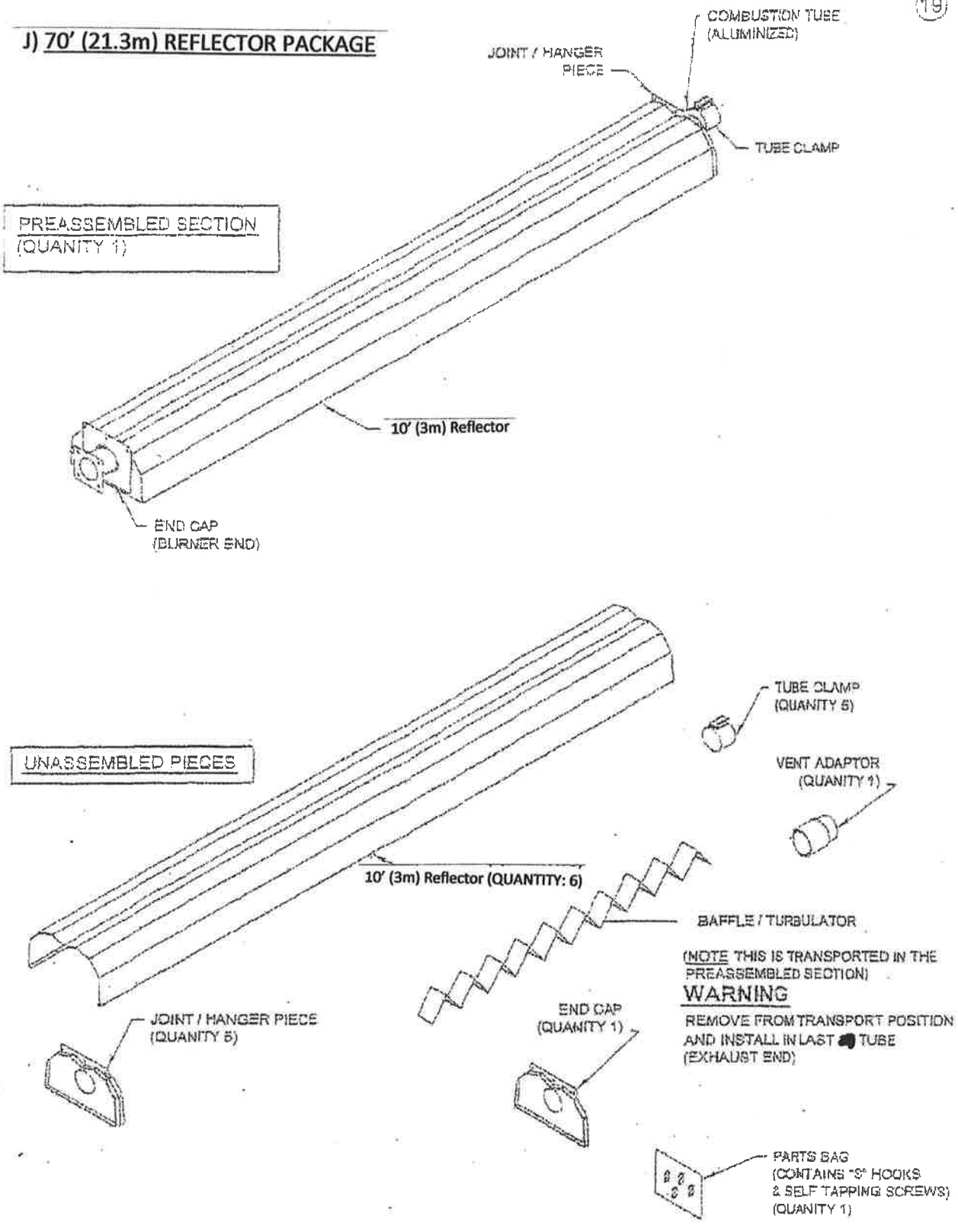

FIGURE#22. 70' (21.3m) Reflector Package Contents

K) 80' (24.4m) REFLECTOR PACKAGE

PREASSEMBLED SECTION
(QUANTITY 1)

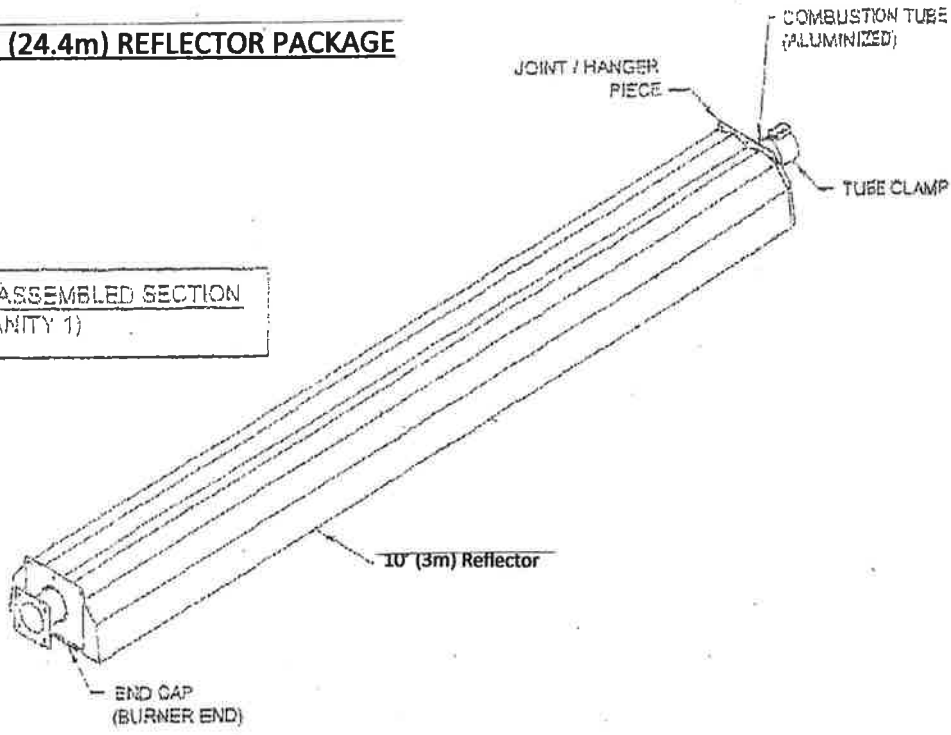

UNASSEMBLED PIECES

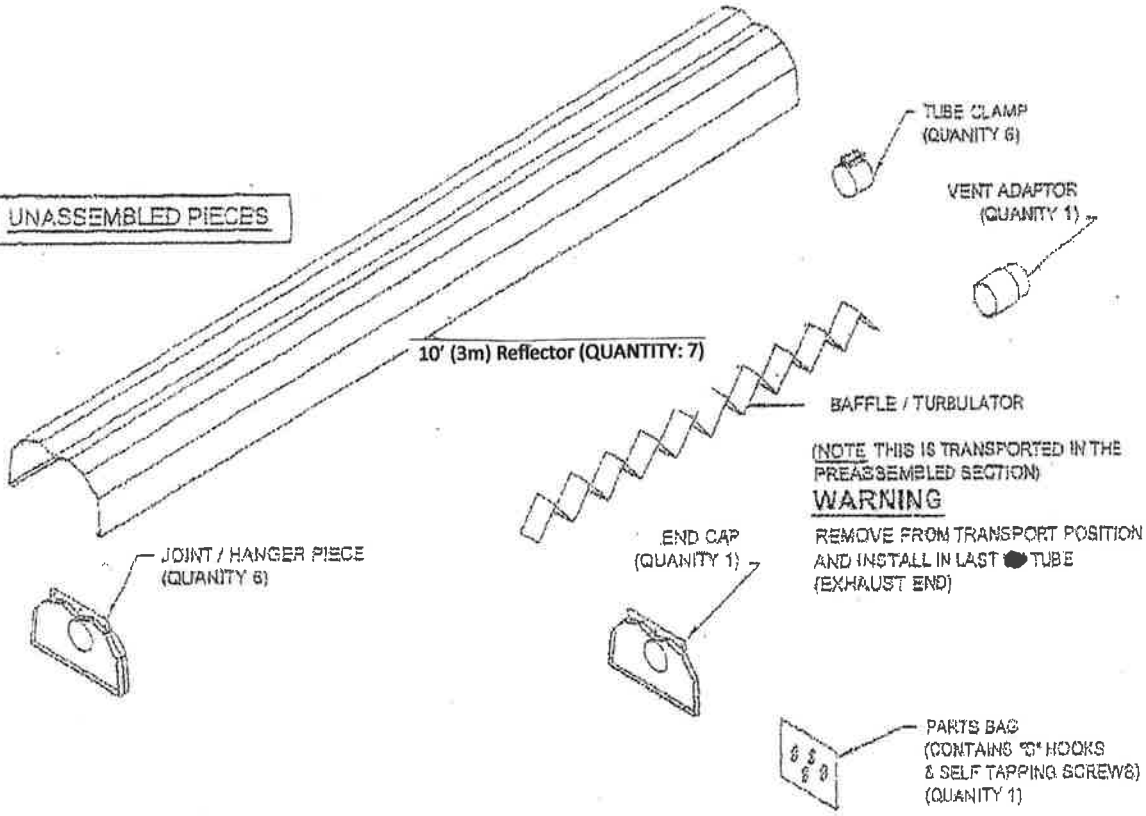

FIGURE#23. 80' (24.4m) Reflector Package Contents

L) 10' (3m) EXTENSION KIT

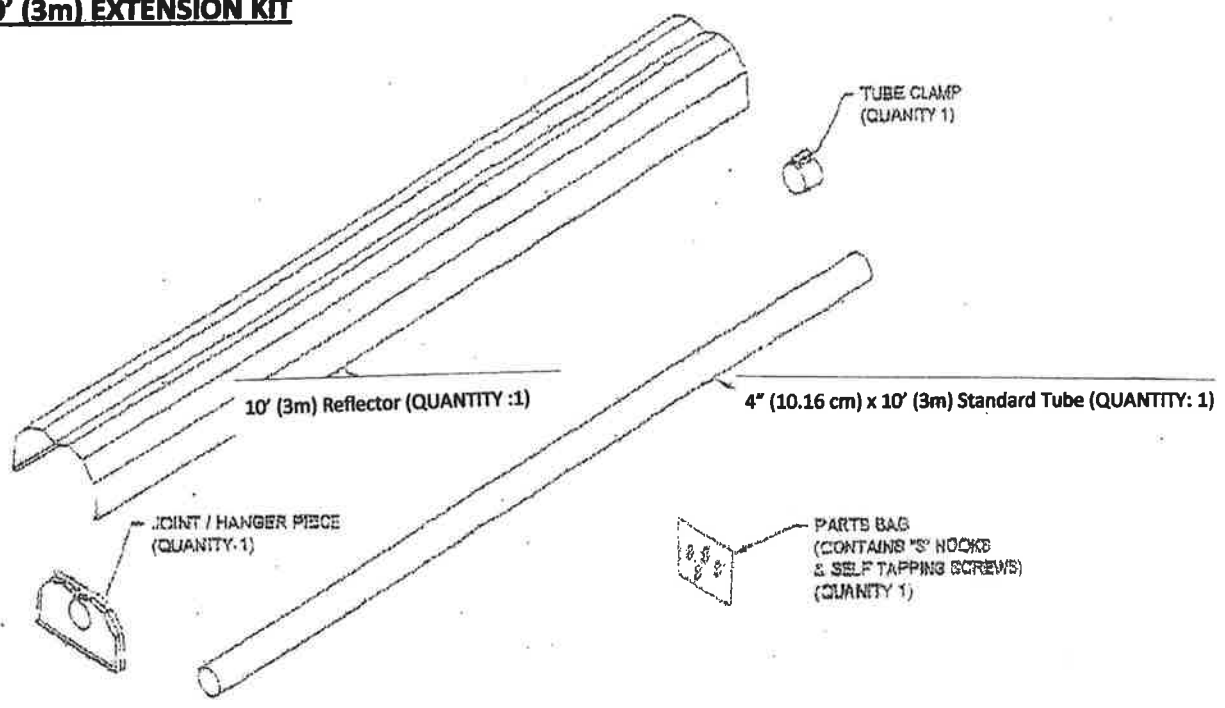

FIGURE #24. 10' (3m) EXTENSION PACKAGE CONTENTS

M) SIDE REFLECTOR PACKAGE

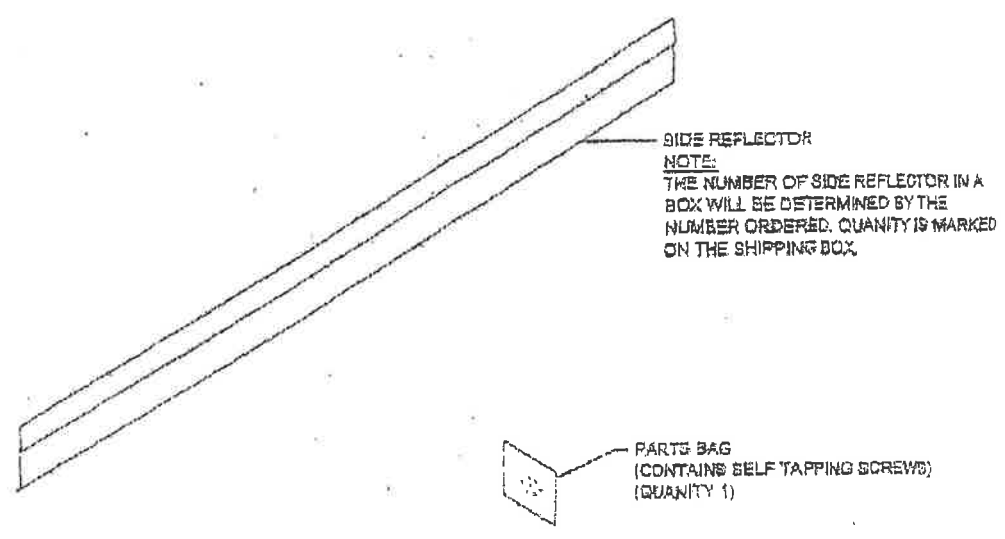

FIGURE #25, SIDE REFLECTOR PACKAGE CONTENTS

N) 90° ELBOW PACKAGE

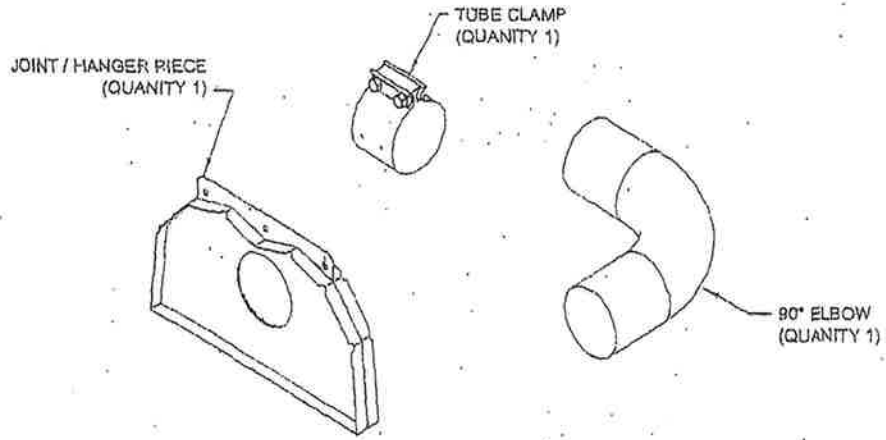

FIGURE #26. 90° ELBOW PACKAGE CONTENTS.

O) 180° U-BEND PACKAGE

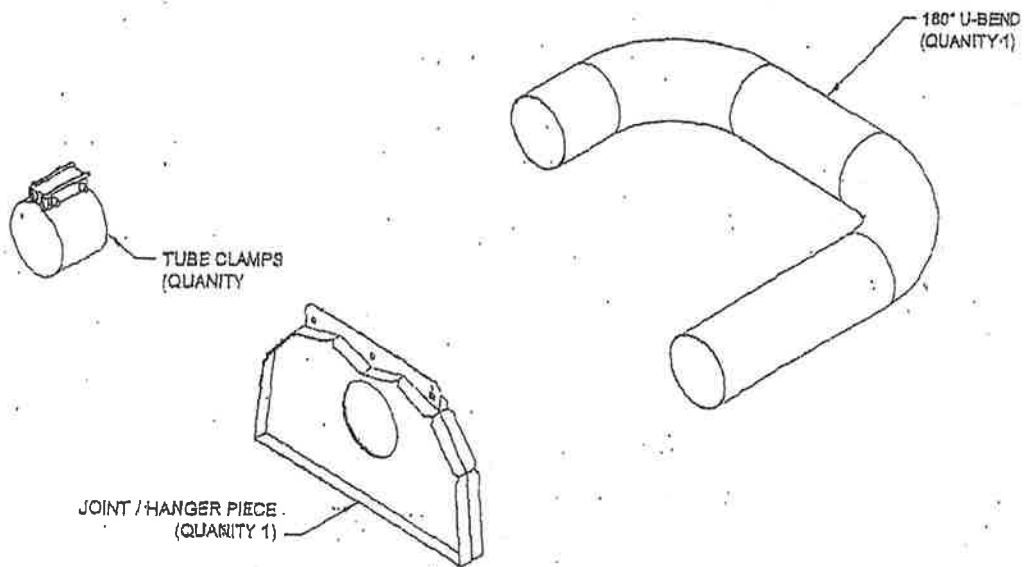

FIGURE #27. 180° U-BEND PACKAGE CONTENTS.

P) SIDE WALL VENT KIT

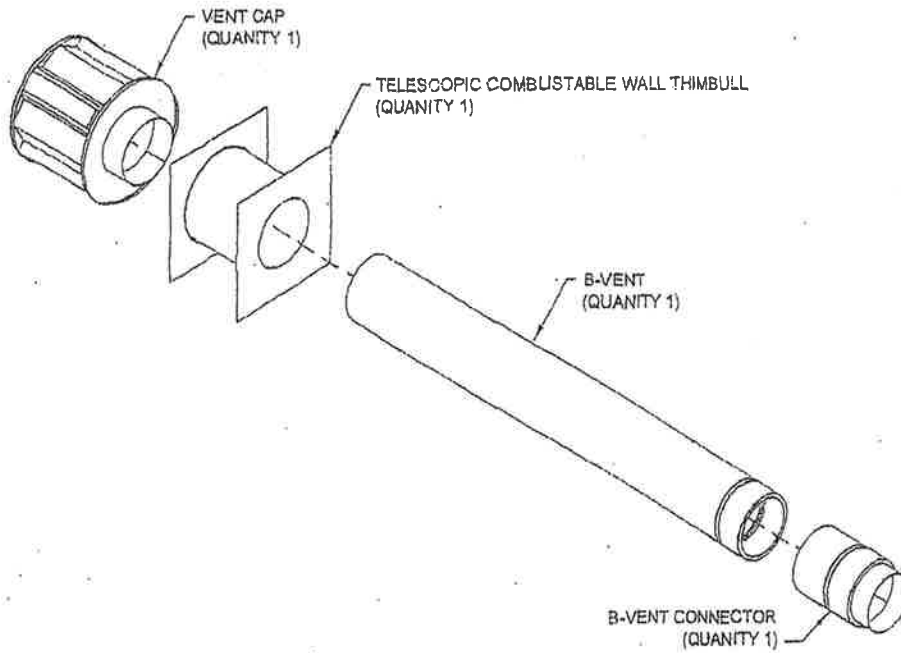

FIGURE #28. SIDE WALL VENT PACKAGE CONTENTS

Q) OUTDOOR INSTALLATION KIT

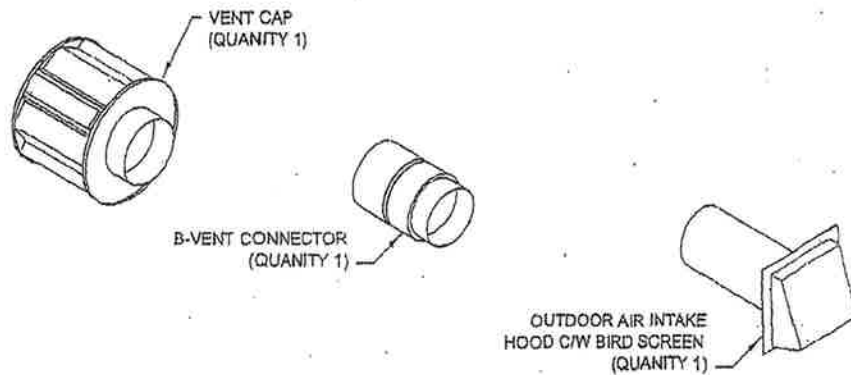

FIGURE #29. OUTDOOR INSTALLATION PACKAGE CONTENTS

INSTALLATION:

Provide for adequate clearance around air openings into the combustion chamber, clearances from combustible material, provisions for accessibility and for combustion and ventilating air supply.

PLANNING:

- Familiarize yourself with the equipment and any accessories that you may require.
- Locate the area where unit is to be installed
- Locate area where any holes might have to be cut for:
 - a) Venting
 - b) Any gas piping requirements
- Make sure that there is no obstruction such as hidden electrical wiring, water lines etc... in the areas of concern.
- Locate the thermostat location.

⚠ WARNING: Observe minimum clearance to combustibles

- Locate the electrical source for unit.
- Measure required amount of various materials required to do the installation, and have these materials on site in an organized manner prior to commencement.

SUSPENSION OF HEATER:

Horizontal Installation:

Locate suspension points on ceiling or roof. Heater is suspended at standard **10' (3m) intervals** (refer to page 25). Adequately secure chains to beam (refer to page 25) suspension points. Hang chains down from suspension point to desired level. Heater is to be hung level. NOTE: Front & rear endcaps are double chained.

Tilt Installation

Refer to page 27, for 25° to 45° tilts. Locate suspension points as described above under the title "Horizontal Installation". It is important NOT to over-tilt the heater. Units are certified for installation up 45°, however the MAXIMUM recommend tilt is no greater than 25°.

⚠ WARNING: It is the responsibility of the installer to use hanging chain that is a minimum of 2/0 or with a minimum support capacity of no less than 75 lbs. Also make sure all suspension points are adequate to support weight of heater and any accessories. Also make sure all S-Hooks are affixed properly and the open ends squeezed closed. If the suspension system fails, it is the responsibility of the installer. A failed suspension system can cause property damage, severe injury and/or death.

Refer to pages 28 & 34 for ASSEMBLY OF COMPONENTS and ASSEMBLY OVERVIEW.

A) SUSPENSION POINTS

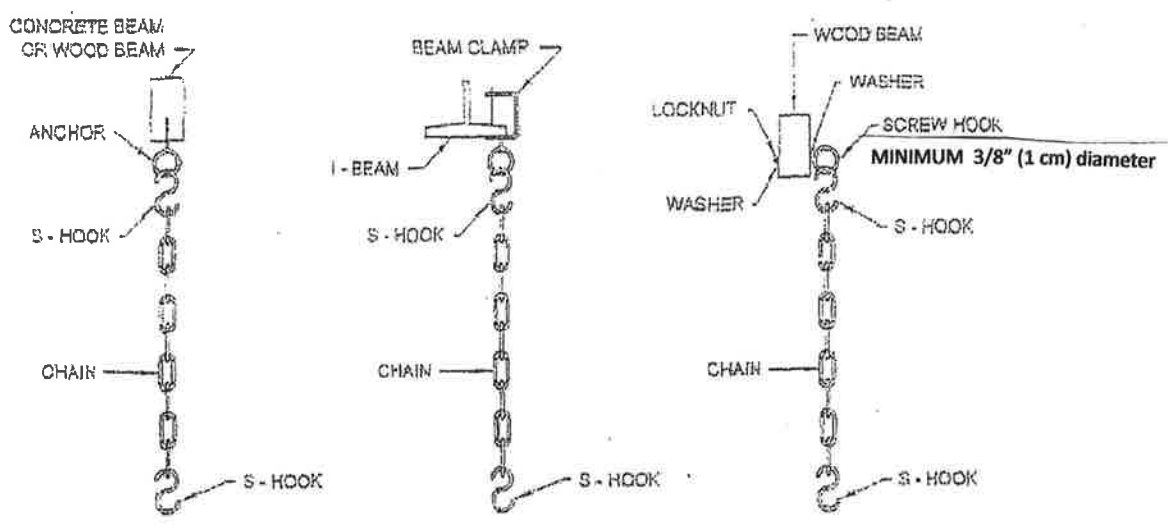

FIGURE #30. EXAMPLE SUSPENSION DETAILS

B) HORIZONTAL INSTALLATION

SUSPENSION LOCATIONS
10' (3m) REFLECTOR PACKAGE

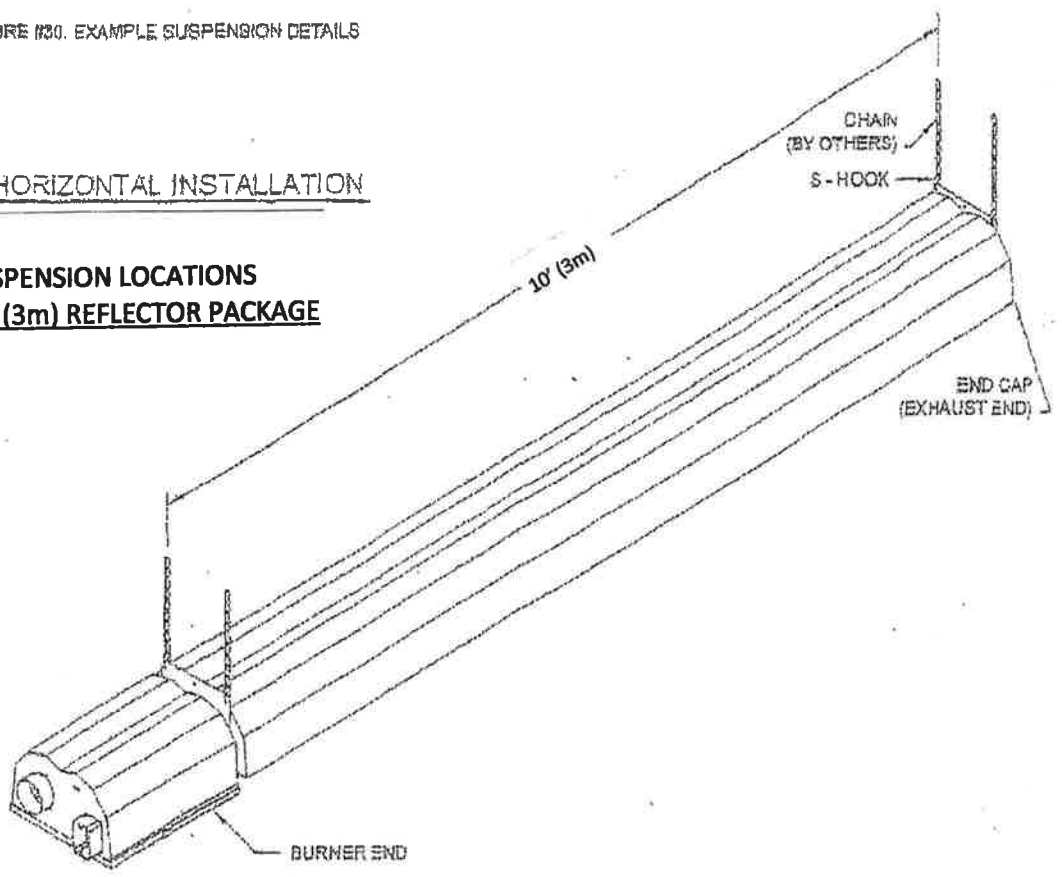

FIGURE #31. HORIZONTAL INSTALLATION - 10' (3m) PACKAGE

C) HORIZONTAL INSTALLATION

SUSPENSION LOCATIONS
15' (4.6m) TO 80' (24.4) Reflector Packages

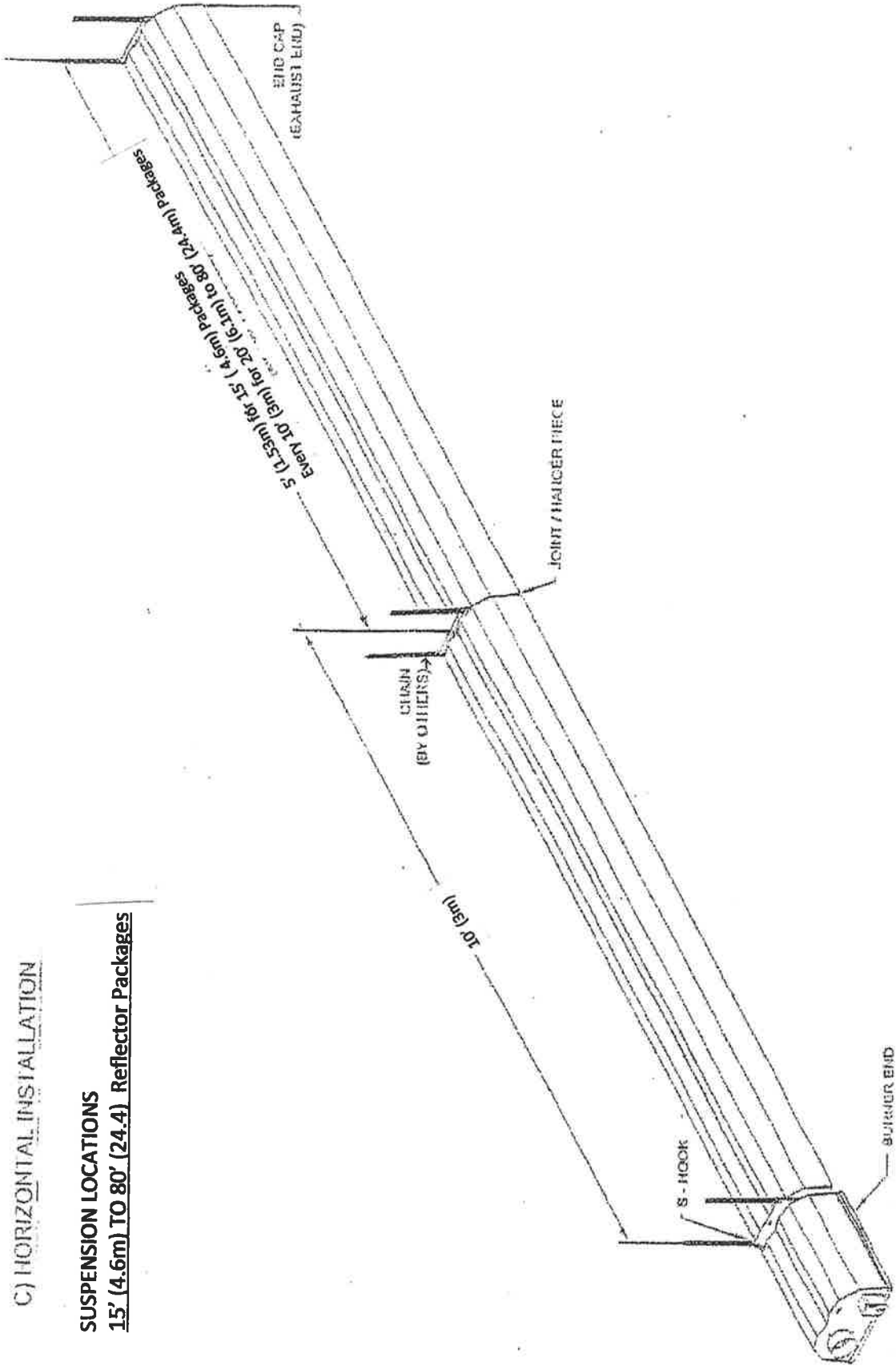

FIGURE # 32. HORIZONTAL INSTALLATIONS - 15' (4.6m) TO 80' (24.4m) PACKAGES

D) 25° TILT (ALL LENGTHS)

NOTE: 25° Tilt is the maximum recommended tilt for most tilt installations.

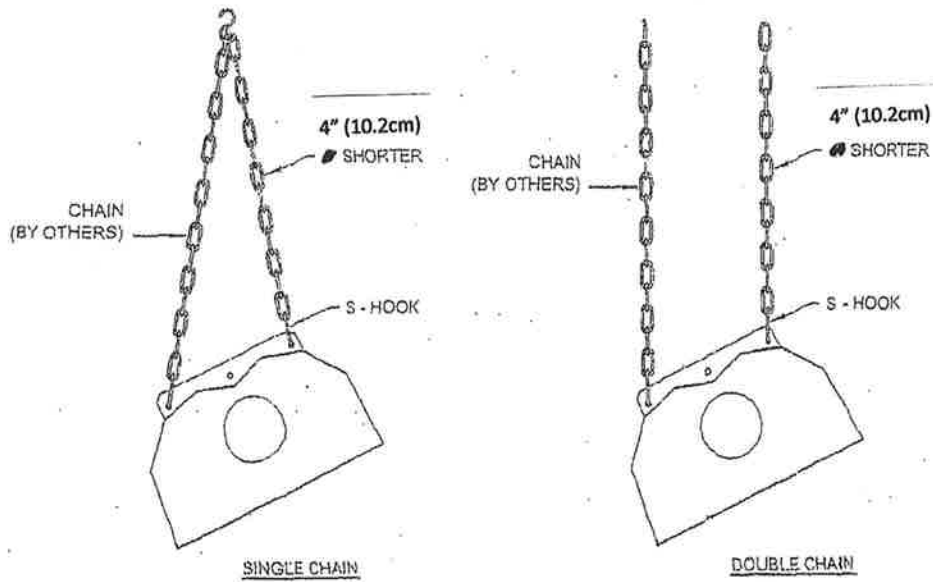

FIGURE #33. 25° TILT

E) 45° TILT (ALL LENGTHS)

NOTE: 45 degree tilt is **NOT RECOMMENDED**. This angle of tilt causes the ambient air to form a convection current over the tube. The net effect of this action is reduced infrared output (decreased heating capacity) as well as decreased exhaust temperature which may increase the chance of condensation of combustion by-products.

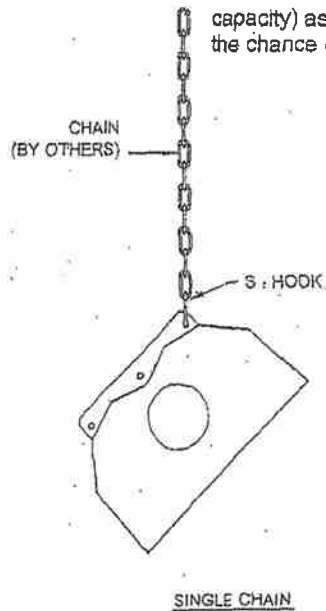

FIGURE #34. 45° TILT

ASSEMBLY OF COMPONENTS

Refer to text & figures in section titled ASSEMBLY OVERVIEW (see page 34 to 46) Refer to COMPONENT ASSEMBLY (see pages 30 to 33)

- 1) **Remove turbulator or baffle from transport location on tube. Set aside as it is to be install in the last 10' (3m) tube of the heater (see page 30). The only exception to this is the 80' (24.5) reflector package. It does not require the turbulator or baffle.**
- 2) **Attach burner head to initial 10' (3m) preassembly (see page 30). MAKE SURE WELDED SEAM IS AT BOTTOM OF TUBE POINTING TOWARD THE FLOOR WHEN HEATER IS INSTALLED.**
- 3) **Install S-hooks into joint hangers. Hang preassembled burner box, combustion tube, and reflector (first 10' (3m) of heater from chains with adequate load rating (see warnings on page 24). NOTE: If you are installing a 40,000 Btu/hr – 10' (3m) unit, your installation is complete.**
- 4) **Secure a joint hanger to one end of the reflector by overlapping reflector onto joint/hanger $\frac{3}{4}$ " (1.9cm) and secure via provided self tapping screws.**

5. Attach the above-assembled reflector to the pre-assembled joint/hanger by overlapping reflector on hanger and securing via provided self-tapping screws. (see page 31)

6. Hang assembly from suspended chains via 'S' hooks.

7. Install radiant tube by positioning one end into joint/hanger and butting the other end to the previously installed radiant tube. Secure tubes with clamp and self-tapping screws.

<p>IMPORTANT: Make sure to secure clamp to tube via self-tapping screws. (see diagram 38 on page 31)</p>

8. Secure remaining joint/hanger pieces to reflectors as per item #4,

9. Install assembled reflectors by:

- a) hanging joint/hanger piece end from the next chain in line for installation
- b) install other end of reflector by over lapping the reflector onto the joint/hanger pieces previously assembled and hung, securing via provided self-tapping screws. (see page 31)

10. Install radiant tubes as per #7.

11. Install reflector end cap into last reflector securing with self-tapping screws. -
12. Hang assembled reflector and end cap via double chains onto end cap end. Over lap other end of the reflector onto joint/hanger piece on previous section. (see page 32) Secure reflector to joint/hanger via self-tapping screws.
13. Install final radiant tube as per #7.
14. Install baffles in final radiant tube (see page 33), **(not required for 80' (24.5m) reflector package)**

IMPORTANT: Install baffle into last piece of radiant tube.

15. Install a flue/vent adaptor. (see page 33)
16. Install reflector support strap, as per #8.
17. Install any accessories as per their related instruction and illustrations contained in this manual.
18. Connect to vent.
19. Connect to outside combustion air. (optional).
20. Connect gas, electricity and controls.

COMPONENT ASSEMBLY
(BAFFLE - TRANSPORT POSITION)

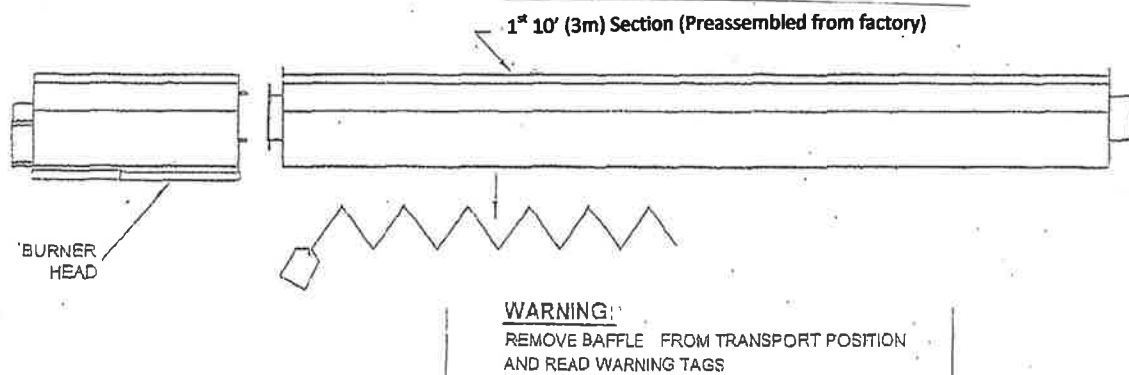

FIGURE #35. BAFFLE / TURBULATOR REMOVAL FROM TRANSPORT POSITION

BURNER HEAD TO FIRST 10' (3m) OF REFLECTOR PACKAGE

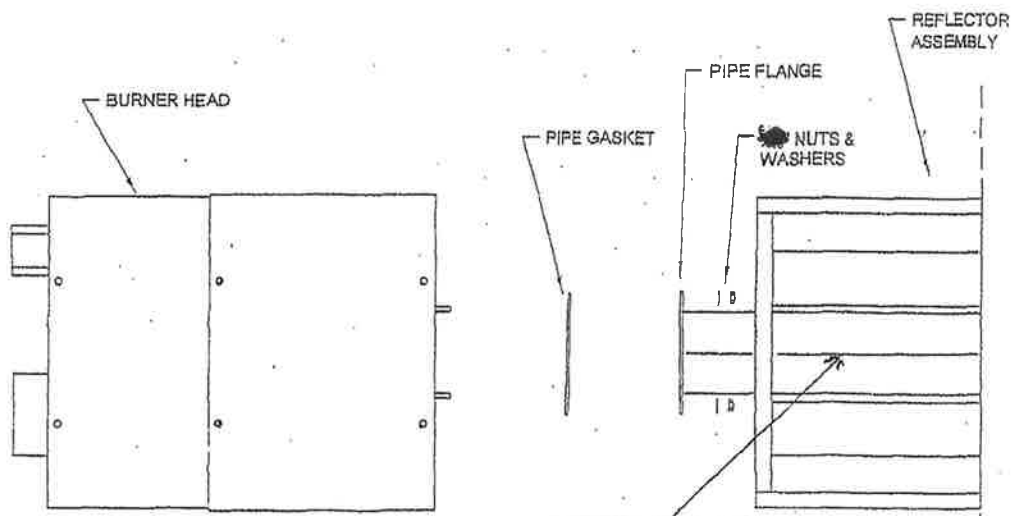

FIGURE #36. BURNER HEAD INSTALLATION

MAKE SURE WELDED SEAMS AT BOTTOM OF TUBE POINTING DOWN TOWARD THE FLOOR WHEN UNIT IS INSTALLED

JOINT HANGER TO REFLECTOR

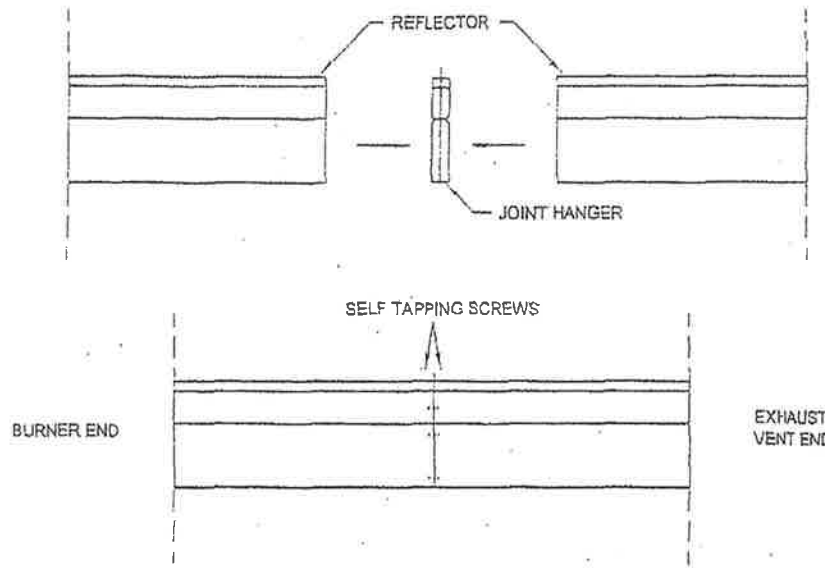

FIGURE #37. JOINT HANGER INSTALLATION

CLAMP COUPLER

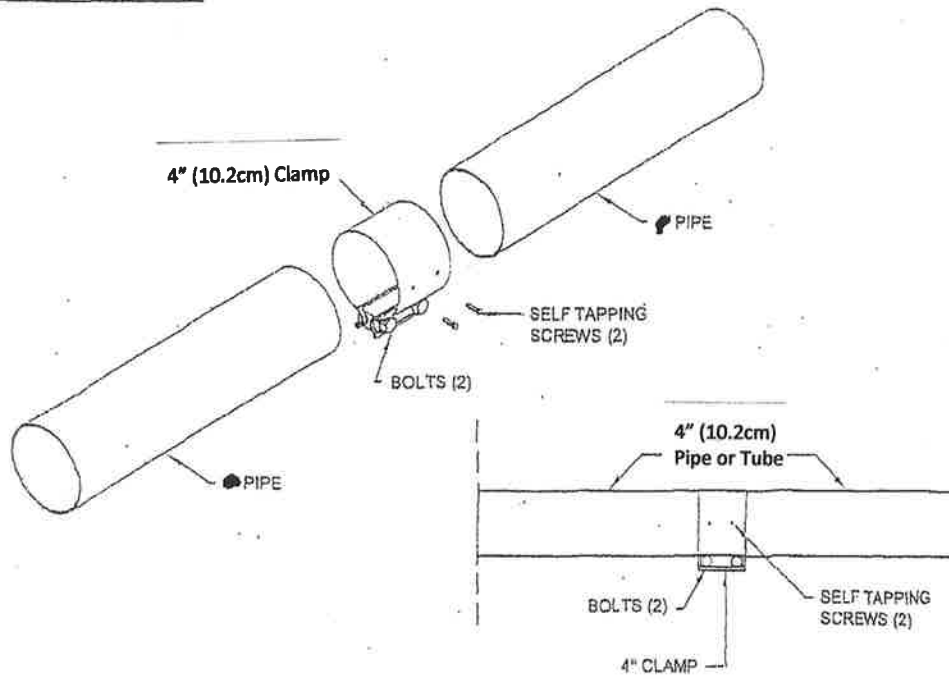

FIGURE #38. CLAMP COUPLER INSTALLATION

END CAP TO REFLECTOR

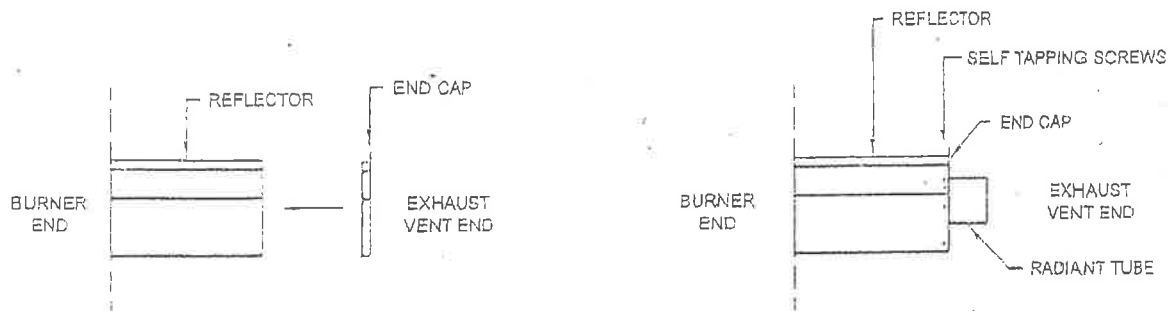

FIGURE #40. END CAP INSTALLATION

BAFFLE/TURBULATOR INSTALLATION

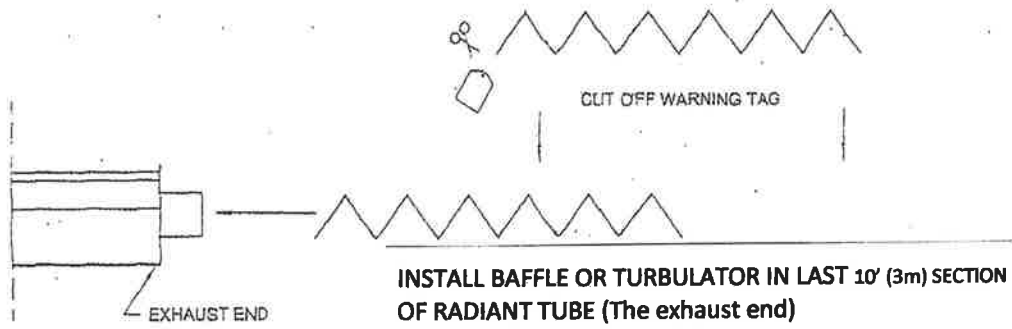

FIGURE #41. BAFFLE / TURBULATOR INSTALLATION

VENT ADAPTOR INSTALLATION

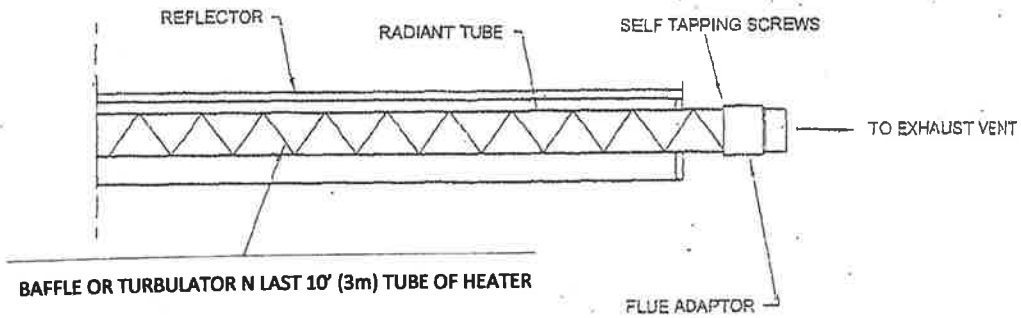

FIGURE #42. BAFFLE / TURBULATOR + FLUE ADAPTOR INSTALLATION

ASSEMBLY (OVERVIEW)

1. Verify length of reflector package to be installed. Read 'ASSEMBLY OF COMPONENTS', on page 25 and view related diagrams on pages 30— 33.
2. Locate section of manual that corresponds with length to be installed. View the corresponding exploded view. The illustration contains the details required to install the unit.

REFLECTOR PACKAGE LENGTH	CORRESPONDING PAGE
10' (3m)	35
15' (4.6m)	36
20' (6.1m)	37
30' (9.1m)	38
40' (12.2m)	39
50' (15.2m)	40
60' (18.3m)	41
70' (21.3m)	42
80' (24.4m)	43

ASSEMBLY OF OPTIONS:

Refer to section of manual containing option to be installed.

Options	Corresponding Page
Sidewall Vent Kit	44
Outdoor Installation Kit	44 & 56
90° Elbow Kit	45
180° U-Bend Kit	45
Side Reflectors	46
Low Voltage Thermostat	64
Line Voltage Thermostat	65

View exploded illustration, install accordingly.

A) 10' (3m) REFLECTOR PACKAGE

NOTE:
THIS REFLECTOR PACKAGE CAN ONLY BE USED WITH THE FOLLOWING INPUTS:
- 40,000 BTU/hr

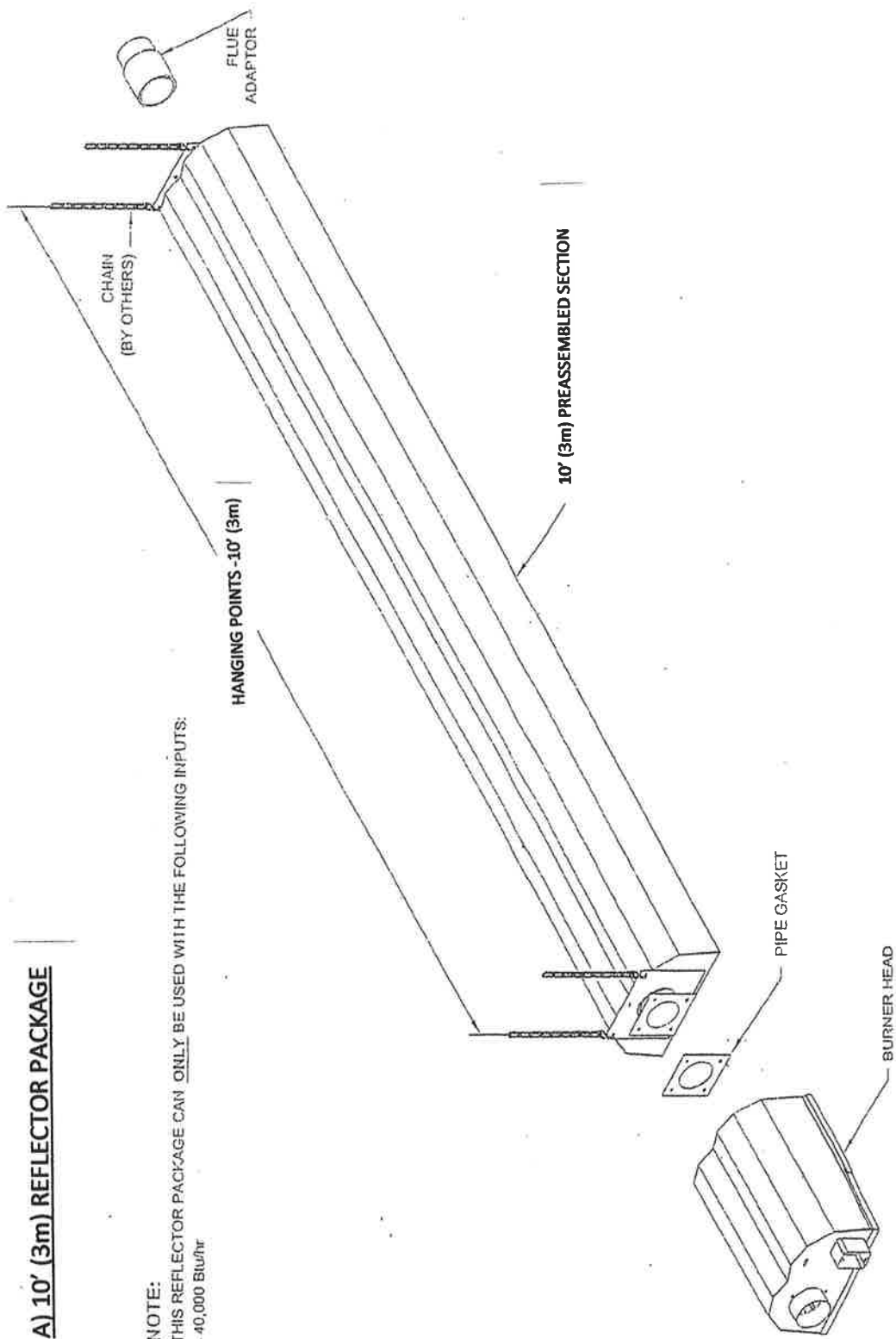

FIGURE#43. 10' (3m) Reflector Package INSTALLATION

B) 15' (4.6m) REFLECTOR PACKAGE

NOTE:
THIS REFLECTOR PACKAGE CAN ONLY BE USED WITH THE FOLLOWING INPUTS:
- 40,000 Btu/hr

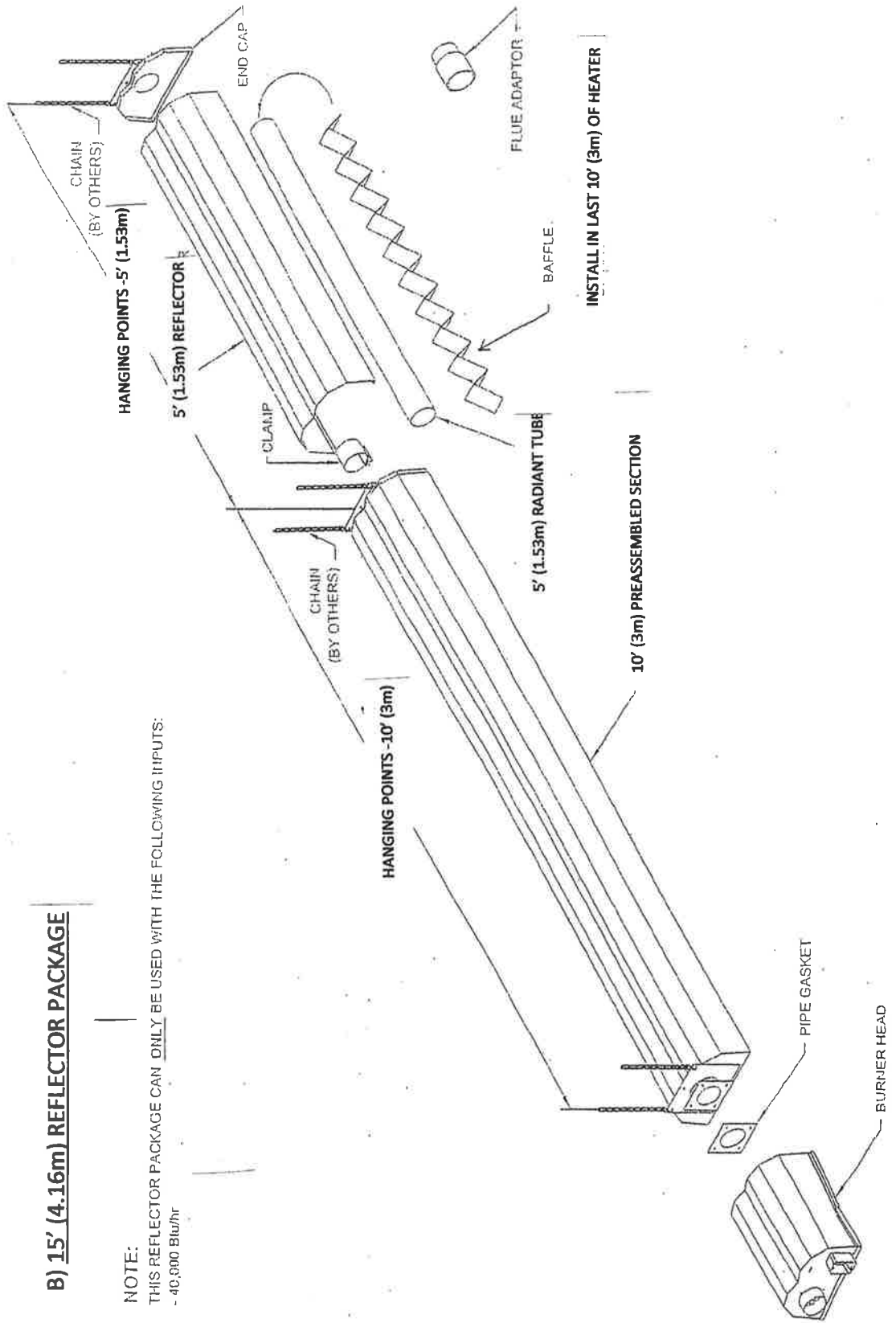

FIGURE#44. 15' (4.6m) Reflector Package INSTALLATION

C) 20' (6.1m) REFLECTOR PACKAGE

NOTE:
THIS REFLECTOR PACKAGE CAN ONLY BE USED WITH THE FOLLOWING INPUTS:

- 40,000 Btu/hr
- 50,000 Btu/hr
- 60,000 Btu/hr
- 75,000 Btu/hr
- 80,000 Btu/hr

PIPE BOXES REQUIRED

QUANTITY	(RADIANT TUBE)	TYPE
1	A	

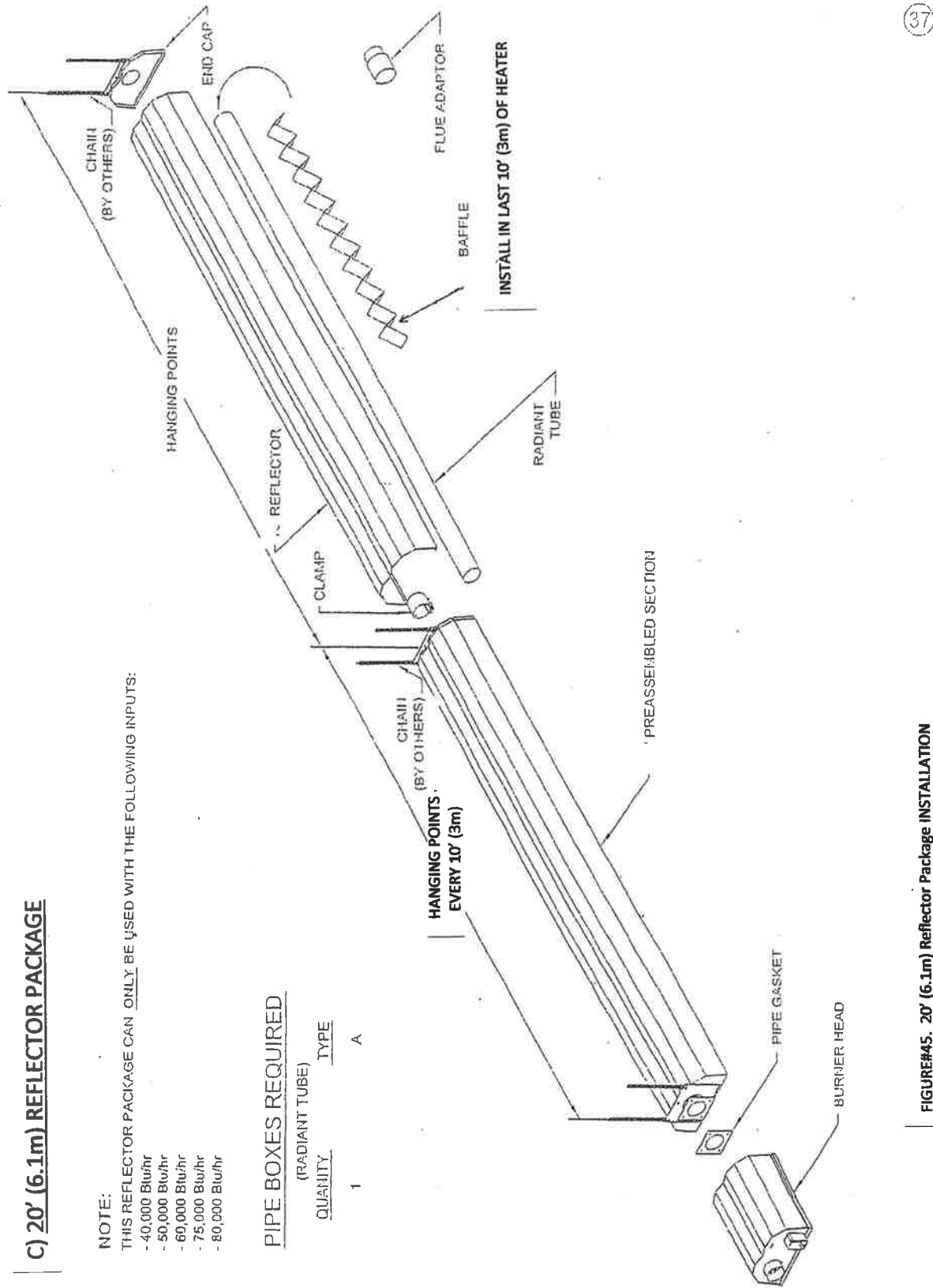

FIGURE#45. 20' (6.1m) Reflector Package INSTALLATION

D) 30' (9.1m) REFLECTOR PACKAGE

NOTE:

THIS REFLECTOR PACKAGE CAN ONLY BE USED WITH THE FOLLOWING INPUTS:

- 60,000 Btu/hr
- 75,000 Btu/hr
- 80,000 Btu/hr
- 100,000 Btu/hr

PIPE BOXES REQUIRED

QUANTITY	(RADIANT TUBE)	TYPE
1		B

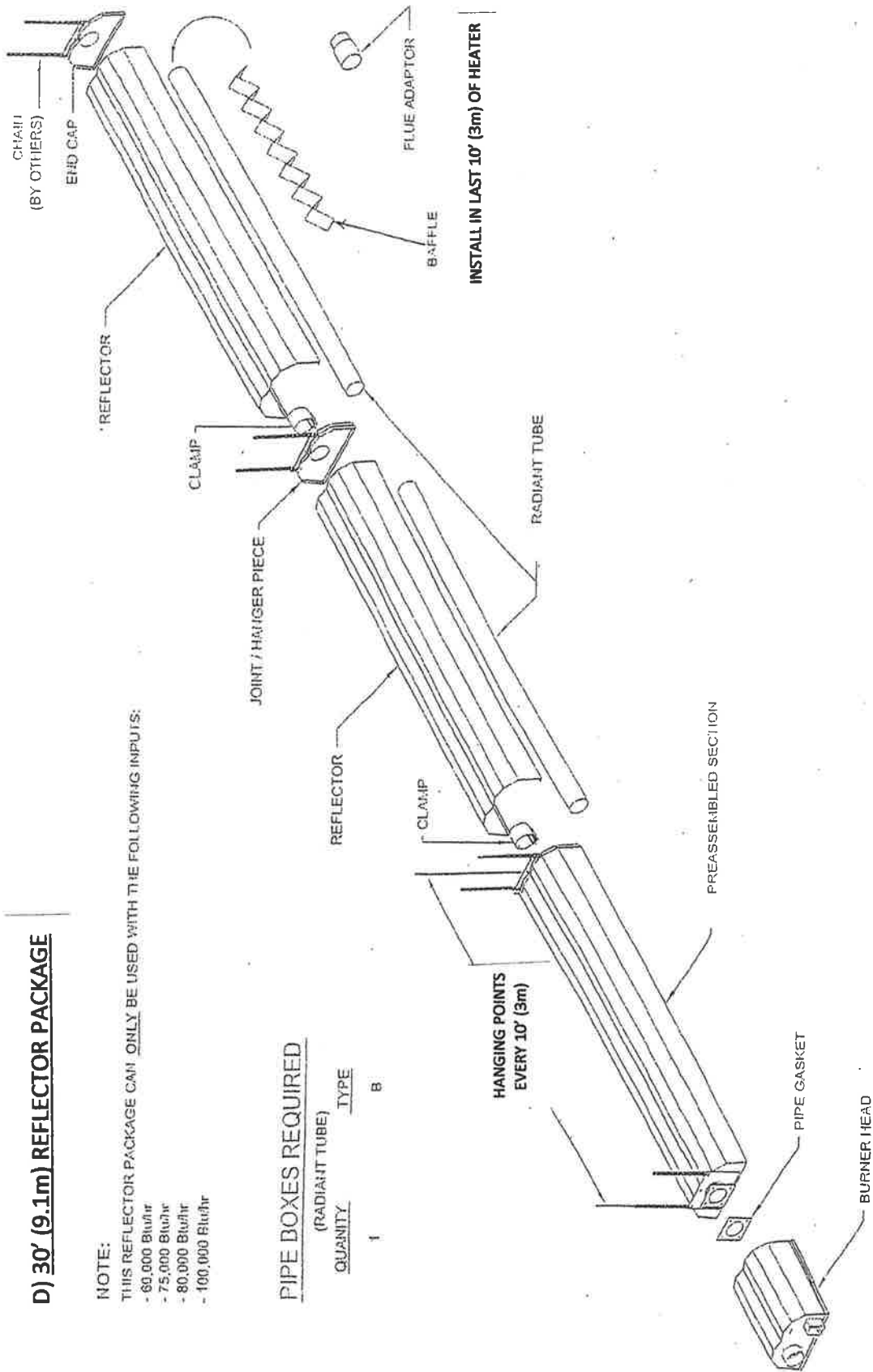

FIGURE#46. 30' (9.1m) Reflector Package INSTALLATION

E) 40' (12.2m) REFLECTOR PACKAGE

NOTE:

THIS REFLECTOR PACKAGE CAN ONLY BE USED WITH THE FOLLOWING INPUTS:

- 60,000 Btu/hr
- 75,000 Btu/hr
- 80,000 Btu/hr
- 100,000 Btu/hr
- 125,000 Btu/hr
- 150,000 Btu/hr

PIPE BOXES REQUIRED

(RADIANT TUBE)

QUANTITY	TYPE
1	A
1	B

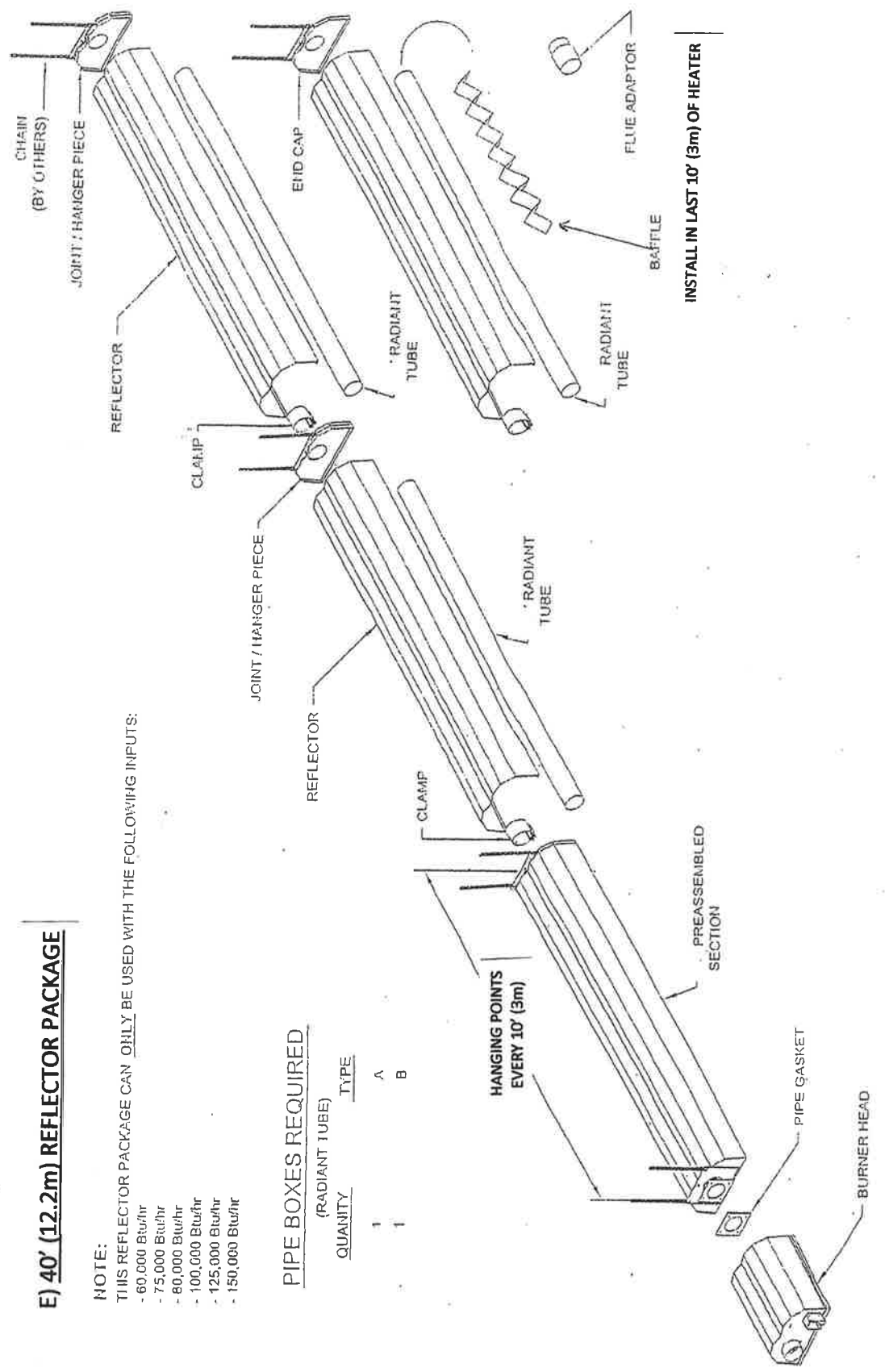

FIGURE#47. 40' (12.2m) Reflector Package INSTALLATION